

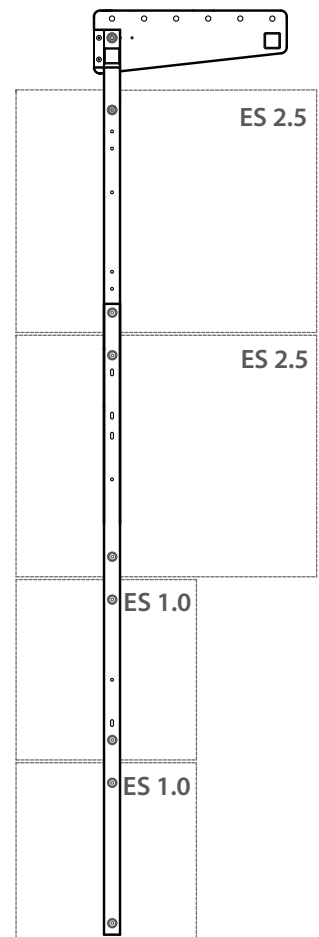

ES Flyware Suspension & Rigging

- Introduction
- Safety Warning
- Parts & Components
- Weights & Strengths
- Configurations



The future of sound.
Made perfectly clear.

At KV2 Audio our vision is to constantly develop technologies that eliminate distortion and loss of information providing a true dynamic representation of the source.

Our aim is to create audio products that absorb you, place you within the performance and deliver a listening experience beyond expectation.

Contents

Contents	3
Introduction	4
Warning	4
Parts & Components	5
Description	6
Weights & Strengths	7
Configurations with Basic Brackets	8
Configurations with Lower Arms	9

Introduction

KV2 Audio presents this manual and instructions for the safe practice, suspension and rigging of the ES Loudspeaker products using the ES Flybar system.

It is important that users familiarize themselves with all the necessary parts, products and instructions as described and indicated in this document before attempting any over-head suspension, flying and rigging.

The ES Loudspeaker enclosures are designed with built in suspension points to facilitate secure flying and rigging providing that no modifications or external parts are substituted and that all instructions are adhered to at all times.

KV2 Audio operates a continuous process of improving and attaining standards: This means that instructions and methods may be subject to change without notification and it is the responsibility of users to check for updated information regarding safe flying procedures.

WARNING! - Safety Rigging

There are accepted 'General Rigging Practises' appropriate to the Entertainment Industry and this document aims to encapsulate them specifically to the KV2 Audio ES Loudspeaker systems described here.

It is vital that only persons whom have experience and prior knowledge of rigging techniques and hardware execute overhead suspension. If in doubt with regards to applying the instructions within this document, then obtain the necessary specialist advice and help, or contact your local KV2 Audio representatives for assistance.

All advice and instructions given and stated within this document are based upon the highest available engineering data from within the country of manufacture , with regards to materials, general practice and is accurate at the time of original printing.

Specifications are subject to change due to constant testing, product refinements and R&D.

Regarding 'General Rigging practises' means that general regulations and requirements are possibly subject to alterations in different Countries and may be superseded locally.

KV2 Audio, as such is not responsible for the safety of any suspension, flying over-head of all specific KV2 Audio Loudspeaker products, or Rigging configurations as executed in practice by users.

It is expressly the sole responsibility of the user to ensure that at all times any KV2 Audio product or system is suspended and rigged in accordance with current International and local regulations.

All non KV2 Audio products such as hoists, clamps, wires, truss, supports used ,or required to suspend KV2 Audio Loudspeaker systems are the sole responsibility of the user.

Parts & Components

The **ES FLYBAR** is a complete system to facilitate the safe suspension of multiple components of the ES series.

Consisting of individual parts that form the basis of attaching the ES Loudspeaker modules to the **FLYBAR**, these are identifiable and described below as:

FLY BAR - 0002 (KVV 987 191)

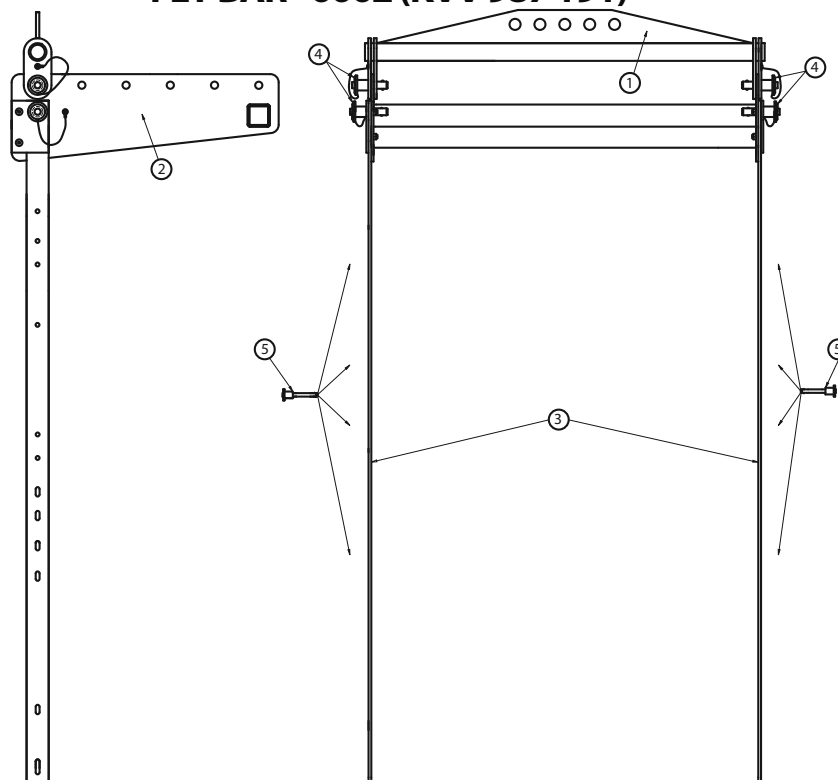

ITEM	QTY	DESCRIPTION
1	1	PICKPOINT Hanging Arm
2	1	MAIN FRAME
3	2	STEEL SUPPORT MOUNT ARM
4	4	D12.6 QUICK RELEASE PIN
5	8	D6 QUICK RELEASE PIN
6	8	M10 x 25 HOLLOW SCREWS

Additional options



ITEM	QTY	DESCRIPTION
1	2	FB-0002 STEEL SUPPORT EXTENSION ARM
2	8	D6 QUICK RELEASE PIN
3	8	M10 x 25 HOLLOW SCREWS

ES DOWNFILL BRACKET (KVV 987 311)

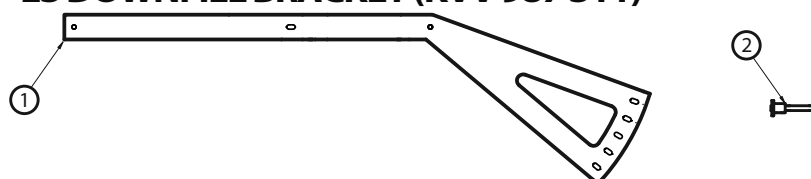

ITEM	QTY	DESCRIPTION
1	2	ES DOWNFILL BRACKET
2	8	D6 QUICK RELEASE PIN
3	8	M10 x 25 HOLLOW SCREWS

Description

FLY BAR - 0002 (KVV 987 191):

The PICKPOINT Hanging Arm is a tubular steel bar that has a line of prefixed apertures in a steel plate along its top edge to allow attachment to hoists, truss and beams.

At each end of the bar is a double steel return at 90 degrees, forming a 'slot' and has a single aperture to receive both the MAIN FRAME and a single D12.6 QUICK RELEASE PIN on each side.

This forms the immediate basis of the complete hanging system and to which all corresponding parts are connected.

The MAIN FRAME is a steel frame consisting of two flat sides with prefixed apertures along its top edge and has two slots on the front end/edge to allow the connection of the STEEL SUPPORT MOUNT ARMS. The flat sides are joined and strengthened by two steel square tubes. The MAIN FRAME is connected to the PICKPOINT Hanging Arm by using a single D12.6 QUICK RELEASE PIN on each side.

The STEEL SUPPORT MOUNT ARMS are pre lengthened steel bars that have multiple apertures that align with the fixing points within the ES enclosures.

These arms are connected to the front edge of the MAIN FRAME sliding into the slot at the front edge and receiving a single D12.6 QUICK RELEASE PIN through the aperture of the arm and the MAIN FRAME each side.

The STEEL SUPPORT MOUNT ARMS receive the ES enclosures and are attached according to the configuration used via D6 QUICK RELEASE PINS.

FB - 0002 ARMS (KVV 987 192):

The FB-0002 STEEL SUPPORT EXTENSION ARM is an optional extension arm that is similar to the STEEL SUPPORT MOUNT ARMS, but is longer in length and uses the same method of attachment via D6 QUICK RELEASE PINS. This is required when suspending multiple enclosures and configurations.

ES DOWNFILL BRACKET (KVV 987 301):

The DOWNFILL BRACKET is a specific steel arm to enable the addition of a single ES1.0 mid hi enclosure to the hang as a down fill module.

The arm is a flat steel -pre lengthened and angled extension, with two apertures to allow connection to the last STEEL SUPPORT EXTENSION ARM by using two D6 QUICK RELEASE PINS on each side.

The ES1.0 down fill enclosure is then attached to the lower pre angled end of the DOWNFILL-BRACKET which has a total of five variant angle options to utilize by using two D6 QUICK RELEASE-PINS on each side.

PLEASE REFER TO THE CONFIGURATIONS PAGES TO ASSURE THE CORRECT STEEL BAR AND PINS ARE USED

Weights & Strengths

The ES Flybar System presents several configurations of system design product combinations for suspension and rigging. Each component has to be factored into the total weight being suspended.

PART	WEIGHT PER UNIT
MAIN FRAME WITH PICK POINT HANG SUPPORT BAR	15 kg (33.07lbs)
VERTICAL STEEL ARM BRACKET	1,6 kg (3.52lbs)
FB - 0002 ARM	1,62 kg (3.57lbs)
ES DOWNFILL BRACKET	2,1 kg (4.63lbs)
TOTAL WEIGHT OF ONE COMPLETE SYSTEM WITH 2 STEEL BARS	18,2 kg (40.13lbs)
TOTAL WEIGHT OF ONE COMPLETE SYSTEM WITH 4 STEEL BARS	21,44 kg (47.27lbs)
MAXIMUM SWL OF ONE COMPLETE SYSTEM WITH 2 STEEL BARS	500kg (1 102.3lbs)
MAXIMUM SWL OF ONE COMPLETE SYSTEM WITH 4 STEEL BARS	500kg (1 102.3lbs)

FOR CERTIFICATION OF FLYBAR COMPONENTS AND PINS PLEASE VISIT www.kv2audio.com

When you use the pins D6 on the speaker system, remove bolts M10x20 and instead install enclosed hollow screws M10x25. Maximum load 500kg.

ES Flybar

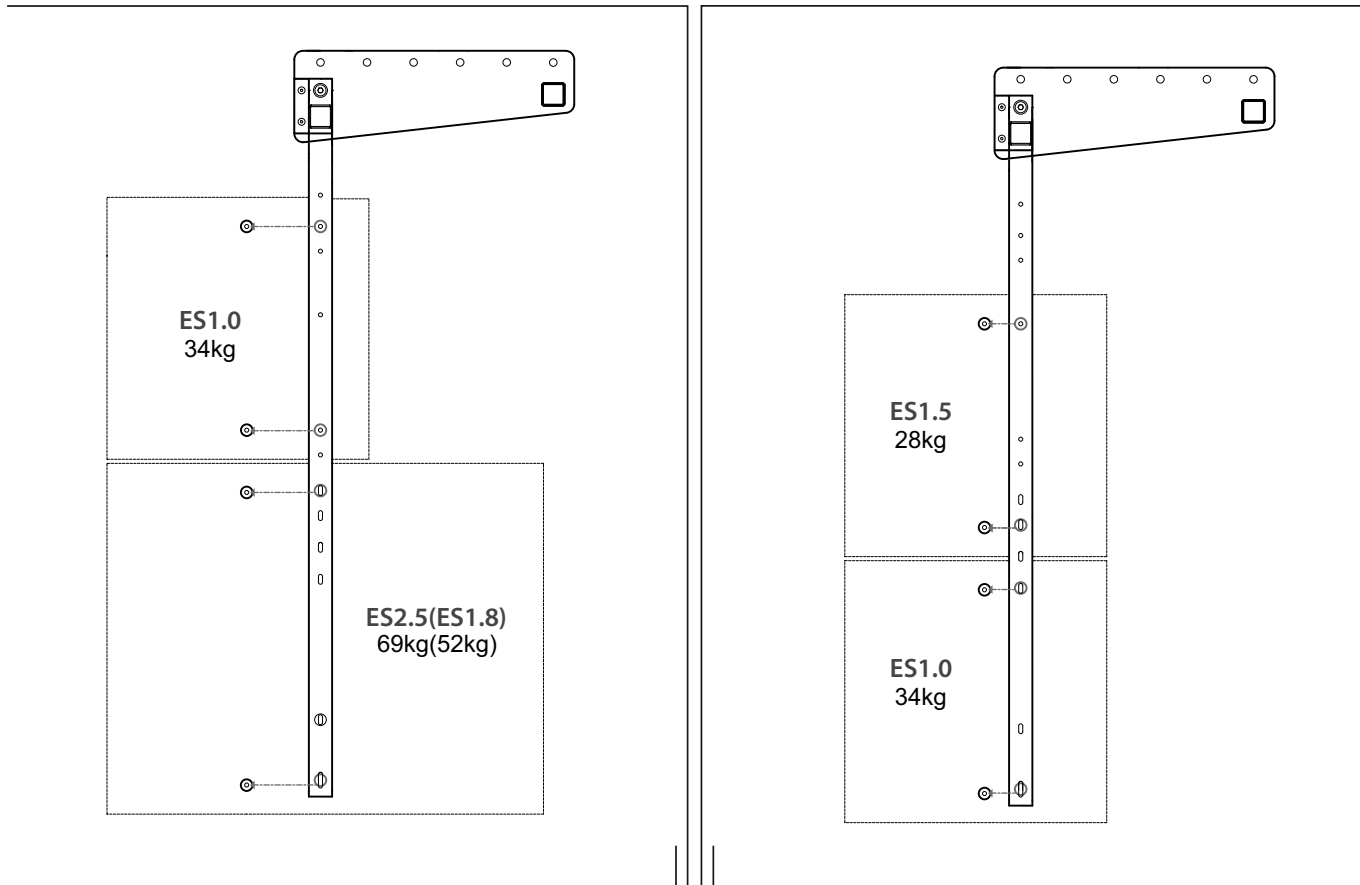

Configurations

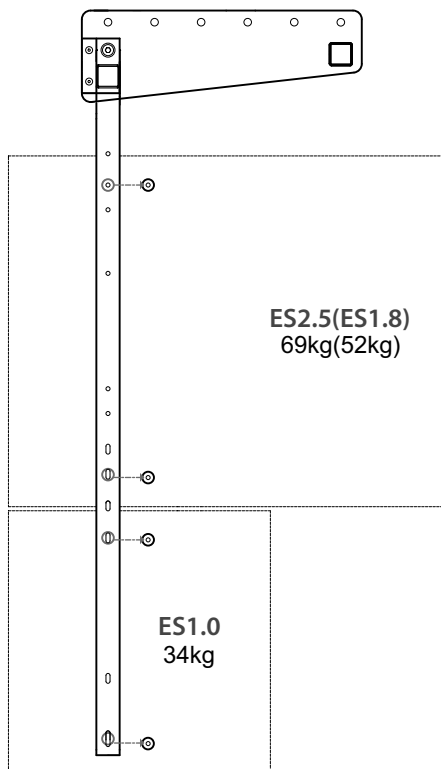

- 8x D6
QUICK RELEASE PIN
(per side)

- 4x D12.6
QUICK RELEASE PIN
(per side)

When you use the pins D6 on the speaker system, remove bolts M10x20 and instead install enclosed hollow screws M10x25. Maximum load 500kg.

FB - 0002 ARMS (KVV 987 192), LOWER ARM SLING



1x FB0002 ARMS per side

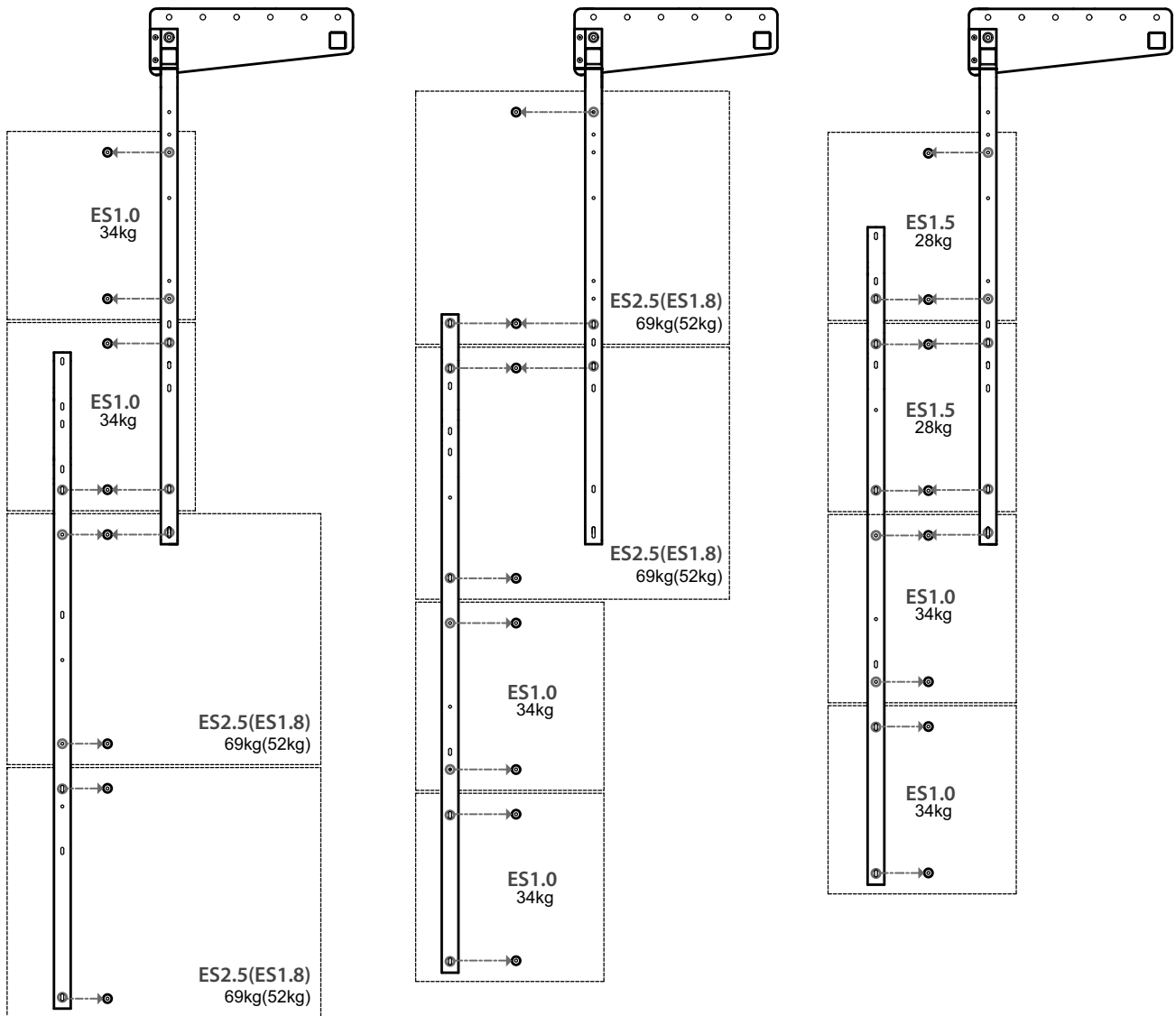

-16x D6 QUICK RELEASE PIN
(per side)

- 4x D12.6 QUICK RELEASE PIN
(per side)

3x FB0002 ARMS per side

1x FB0002 ARMS per side

1x ES DOWNFILL FLYBAR per side

ES Flybar

Configurations

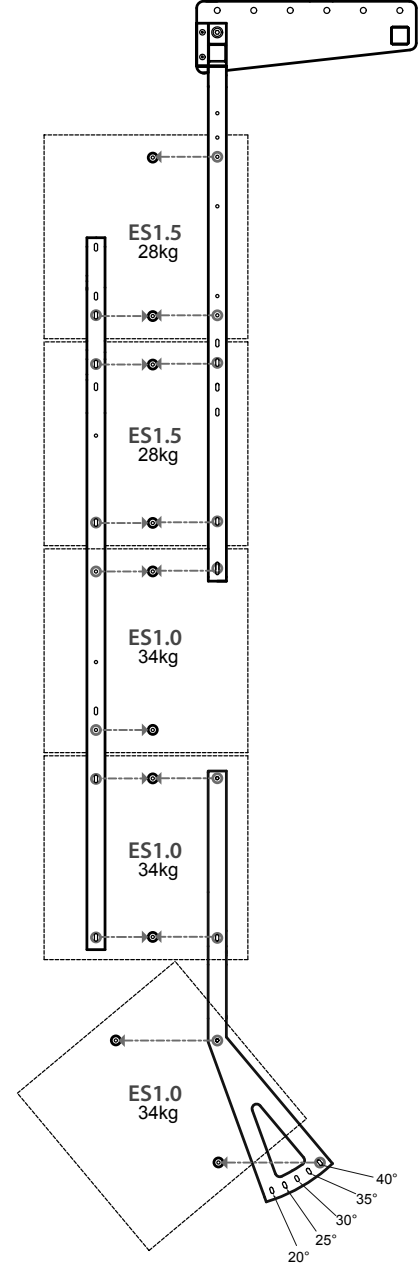
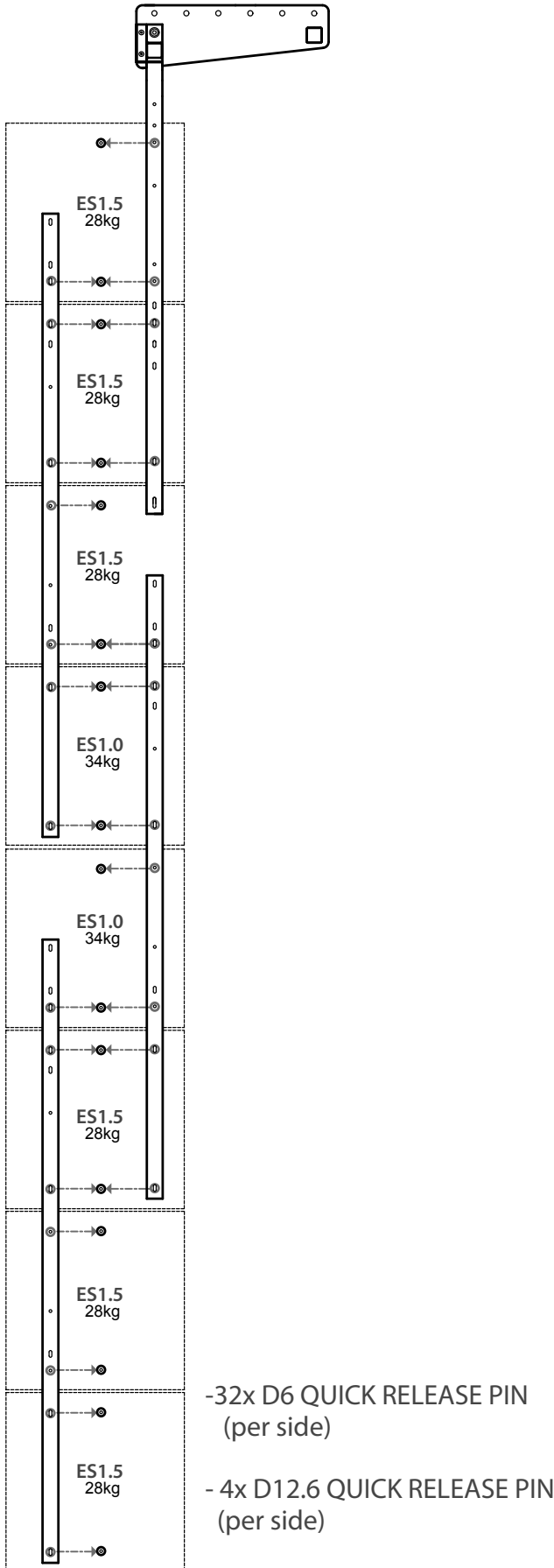

The future of sound. Made perfectly clear.

At KV2 Audio our vision is to constantly develop technologies that eliminate distortion and loss of information providing a true dynamic representation of the source.

Our aim is to create audio products that absorb you, place you within the performance and deliver a listening experience beyond expectation.



KV2 Audio, Nádražní 936, 399 01 Milevsko, Czech Republic
T +44(0)1423 816868 F +44(0)1423 816869
www.kv2audio.com