



EX Series Speakers

User Guide

• EX6 • EX26 • EX10 • EX28 • EX12 • EX15



EX Series Speakers · Important Safety Instructions

Important Safety Instructions

Before using your EX Series Speakers, be sure to carefully read the applicable items of these operating instructions and the safety suggestions.

1. Read all product instructions.
2. Keep printed instructions, do not throw away.
3. Respect and review all warnings.
4. Follow all instructions.
5. Do not use this unit near water, in unprotected out door areas or in rain or wet conditions.
6. Clean only with dry cloth.
7. Do not block any ventilation openings.
8. Install in accordance with KV2 Audio's recommended installation instructions.
9. Do not install near any heat sources such as heat radiators, heat registers, stoves or other apparatus that produce heat.
10. Do not defeat the safety purpose of the grounding type plug. A grounding type plug has two blades and a third grounding connector. The third connector is provided for your safety. If the provided plug does not fit into your outlet, consult an electrician for replacement of the obsolete outlet.
11. Protect the power cord from being walked on or pinched, particularly at plugs, convenience receptacles. The AC mains plug or appliance coupler shall remain readily accessible for operation.
12. Only use accessories specified by KV2 Audio.
13. Install the product only with rigging specified by KV2 Audio, or sold with the loudspeaker.
14. Unplug this loudspeaker during lightning storms or when unused for long periods of time.
15. Refer all servicing to qualified service personnel. Servicing is required when the loudspeaker has been damaged in any way, such as when the power-supply cord or plug has been damaged; liquid has been spilled or objects have fallen into the loudspeaker; rain or moisture has entered the loudspeaker; the loudspeaker has been dropped; or when for undetermined reasons the loudspeaker does not operate normally.
16. Do not remove front or back panels. Removal of the panel will expose hazardous voltages. There are no user serviceable parts inside and removable may void the warranty.
17. An experienced user shall always supervise this professional audio equipment.

**CAUTION: TO REDUCE THE RISK OF ELECTRIC SHOCK, DO NOT REMOVE THE PANELS.
NO USER-SERVICEABLE PARTS INSIDE. REFER SERVICING TO QUALIFIED PERSONNEL.**

WARNING: To prevent fire or electric shock, do not expose this equipment to rain or moisture.

SAFETY SUMMARY

To reduce the risk of electric shock, disconnect the loudspeaker from the AC mains before installing audio cable. Reconnect the power cord only after making all signal connections. Connect the loudspeaker to a twopole, three-wire grounding mains receptacle. The receptacle must be connected to a fuse or circuit breaker. Connection to any other type of receptacle poses a shock hazard and may violate local electrical codes. Do not allow water or any foreign object to get inside the loudspeaker. Do not put objects containing liquid on or near the unit. To reduce the risk of overheating the loudspeaker, avoid exposing it to direct sunlight. Do not install the unit near heat-emitting appliances, such as a room heater or stove. This loudspeaker contains potentially hazardous voltages. Do not attempt to disassemble the unit. The unit contains no user serviceable parts, repairs should be performed only by factory trained service personnel.

Contents

EX6	4
Overview	4 - 5
AC Power Requirements	6 - 7
Audio Signal	8 - 9
Specifications	10
Frequency characteristics	11
Using Multiple Boxes	12
Drawings	13
EX26	14
Overview	14 - 15
AC Power Requirements	16 - 17
Audio Signal	18 - 19
Specifications	20
Frequency characteristics	21
Using Multiple Boxes, Drawings	22 - 23
EX10	24
Overview	24 - 25
AC Power Requirements	26 - 27
Audio Signal	28 - 29
Specifications	30
Frequency characteristics	31
Drawings	32
EX28	33
Overview	33 - 34
AC Power Requirements	35 - 36
Audio Signal	37 - 38
Specifications	39
Frequency characteristics	40
Drawings	41
EX12	42
Overview	42 - 43
AC Power Requirements	44 - 45
Audio Signal	46 - 47
Specifications	48
Frequency characteristics	49
Drawings	50
EX15	51
Overview	51 - 52
AC Power Requirements	53 - 54
Audio Signal	55 - 56
Specifications	57
Frequency characteristics	58
Drawings	59
Accessories	60 - 64
Rotating the EX10 / EX12 Horn	64
Warranty · Service	65

EX6 FULL RANGE MODULE

ACTIVE

200 WATT EXTREME RESOLUTION SPEAKER SYSTEM

EX6 - part number KVV 987 139 (230V)
KVV 987 138 (115V)



Application

Specifically designed for reproduction of recorded music in near field applications

- Suitable in Fixed installations as full range stand-alone or with subwoofers
- Excellent peripheral re-enforcement for main KV2 systems
- Portable PA for Multi-Media applications
- Compact floor monitoring solutions
- Domestic and Professional studio monitoring

Introduction

The EX6 is a 2-way high output, active, compact, full-range speaker system. Design objectives for the EX6 were focused on the expansion of KV2 Audio's primary philosophy of speakers systems with increased dynamic range, very high output and a consistent sound character no matter what the output level. The EX6 sets new levels of performance for compact cabinets achieved through the integration of new amplifier, transducer and electronic control technologies that are closely tied to a passion for taking performance to the next level.

Electronics

Amplifier power, electronic crossovers, phase alignment, equalisation and speaker protection are integrated into the EX6's amplifier module.

The EX6's high frequency compression driver is powered and controlled by KV2 Audio's standard low intermodulation distortion, Class A/B, push-pull circuitry, designed to produce the lowest intermodulation distortion possible and the highest audio quality in the critical mid and high operating bands.

An improved version of KV2 Audio's current enhancing, Bass driver switching amplifier has been developed for the EX6. The new configuration improves overall system efficiency and increases output, allowing passive radiation of heat to take place through a unique "fin-less" heat sink that can be placed in any position or direction. Additionally, the EX6 amplifier unit contains an internally located electric fan that is operated by a temperature sensing circuit which will slowly bring the fan online as required.

Acoustic Components

KV2 Audio has developed a revolutionary woofer technology called Trans-Coil™. The woofer has two coils, a standard voice coil assembly and a second coil placed directly on the neodymium magnetic circuit's pole piece. This technology eliminates voice coil inductance resulting in a flat impedance response above the resonance point and achieves faster transient response through increased force and control of the moving mass. It also linearises acoustic and electrical phase response, reduces harmonic distortion and increases power transfer and transducer speed. Through this technology, the speaker now behaves like both a woofer at lower frequencies and like a mid-range at higher frequencies allowing a seamless transition to take place at the crossover frequency.

The EX6's patent pending NVPD neodymium compression driver is loaded on a constant directivity horn designed for smooth, wide dispersion performance. More importantly, it has also been designed to precisely match the power response of the woofer at the crossover frequency, a crucial design objective that ensures smooth transition and minimizes anomalies.

The EX6 horn design is based on constant- directivity geometry with an emphasis on generating very low air distortion artifacts, maintaining low transducer compression ratios, high output and wide dispersion (100° x 100°).

The horn is an injected molded aluminium part that functions as a heat dissipater for the compression driver's neodymium magnetic motor structure.

Enclosure Design

The EX6 is a very compact, asymmetrical geometry enclosure design allowing it to be used in a variety of applications.

A specially moulded aluminium handle was designed and fitted to the top of the cabinet. It functions as the principle pick up handle as well as providing several fixed installation and hanging solutions. It has a centrally located M10 hang point as well as four additional M6 bracket points found underneath the KV2 logo.

The handle's M10 point is used alongside a similar M10 point on the bottom of the box when utilising an EX6 Horizontal Bracket.

Four principal mounting bolts also provide an Omnimount™ bracket point.

There are two side-mounted M10 hang points that can be used with the EX6 Vertical Bracket or eyebolts.

The optional Pole mount adaptor sits over the two lugs on the rear of the cabinet and slides upwards-locking into place and supporting the bottom and rear of the cabinet.

AC Power

The EX6 uses a PowerCon 3-pole AC main system with locking connectors to prevent accidental disconnection. The main AC connector (blue) serves as the power input.

The EX6 operates in either 115 V or 230 V modes. Although pre-configured at the factory, the unit's operating voltage mode can be changed in the field.

Voltage Requirements

The EX6 operates safely and without audio discontinuity if the AC voltage stays within the operating window of 100 V–130 V in 115 V mode and 200 V–250 V when working in 230 V mode, at 50 or 60 Hz.

If the On LED does not illuminate or the system does not respond to audio input, remove AC power immediately. Verify that the voltage is within the proper range. If the problem persists, please contact KV2 Audio or an authorized service center.

If the voltage drops below the low boundary of its safe operating range, the loudspeaker will shut down if the voltage does not rise above the low boundary before storage circuits are depleted. How long the loudspeaker will continue to function during brownout depends on the amount of voltage drop and the audio source level during the drop. If the voltage increases above the upper boundary of the range, the power supply can be damaged.

It is recommended that the voltage supply be within the rated voltage window. This ensures that AC voltage variations from the service entry -or peak voltage drops due to cable runs - do not cause the amplifier to cycle on and off or cause damage to the power supply.

For best performance, the AC cable voltage drop should not exceed 10 volts, or 10 percent at 115 volts and 5 percent at 230 volts.

Make sure that even with the AC voltage drop, the AC voltage always stays within recommended operating ranges. The minimum electrical service amperage required by an EX6 speaker system is the sum of each loudspeaker's maximum continuous rms current. An additional 50 percent above that amperage is recommended to prevent peak voltage drops at the service entry.

The Power Connector

The EX6 requires a grounded outlet. It is very important that the loudspeaker AC supply be properly grounded in order to operate safely and properly. Use the PowerCon AC cable-wiring diagram overleaf to create inter-national or special-purpose power connectors:

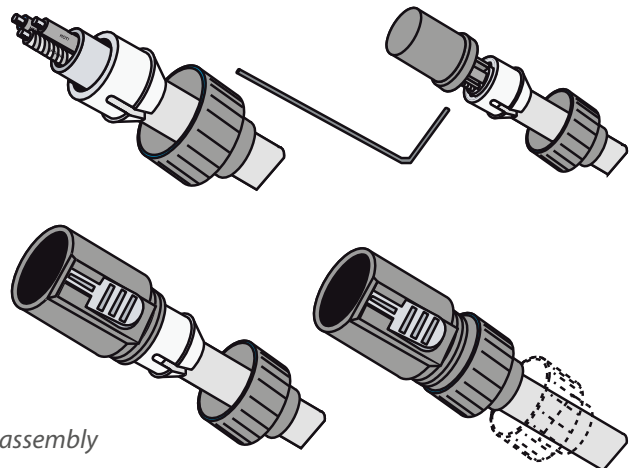

Power connector assembly

Current Requirements

Each EX6 requires approximately 2.5 Amps max at 115 V AC for proper operation. This allows up to six EX6's to be powered from one 15 A breaker at 115 V and up to twelve EX6's at 230 V.

The EX6 presents a dynamic load to the AC mains, which causes the amount of current to fluctuate depending on quiet or loud operating levels. Since different cables and circuit breakers heat up at varying rates, it is essential to understand the types of current ratings and how they correspond to circuit breaker and cable specifications.

The maximum long-term continuous current is the maximum rms current during a period of at least ten seconds. It is used to calculate the temperature rise in cables, in order to select a cable size and gauge that conforms to electrical code standards. It is also used to select the rating for slow-reacting thermal breakers.

The burst current is the maximum rms current during a period of approximately one second, used to select the rating of most magnetic breakers and to calculate the peak voltage drop in long AC cables according to the formula:
 $V_{pk}(\text{drop}) = I_{pk} \times R(\text{cable total})$

The ultimate short-term peak current is used to select the rating of fast reacting magnetic breakers. Use the table below as a guide when selecting cable gauge size and circuit breaker ratings for your operating voltage.

Current Draw	115 V Mode	230 V Mode
Max Long Term Continuous	2.5 A rms	1.25 A rms
Burst Current	3.75 A rms	1.85 A rms
Short Term Peak	10 A peak	5 A peak

AC Cable Color Coding

If the colours referred to in the diagram don't correspond to the terminals in your plug, use the following guidelines: *Connect the blue wire to the terminal marked with a N or coloured black. Connect the brown wire to the terminal marked with a L or coloured red. Connect the green and yellow wire to the terminal marked with a E or coloured green or green and yellow.*

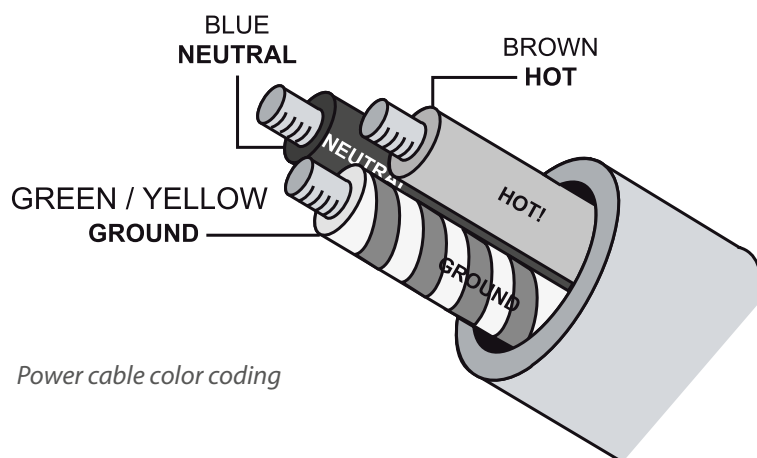

Power cable color coding

The EX6 requires a ground connection. Always use a grounded outlet and plug.

The EX6 Control Panel

The EX6 features an easy to use control panel featuring AC power in, audio input and output, level control, LED status light and a High Pass filter.



EX6 Rear panel

Audio Input and Output

The EX6 uses a balanced, female XLR connector for the audio input connector, and a male XLR connector to provide through output signal. The through output connector, wired in parallel to the audio input, will continue to provide the input signal if the EX6 is turned off. The audio input circuit presents a 20 k Ω balanced input impedance to a three-pin XLR connector with the following connections:



Main input

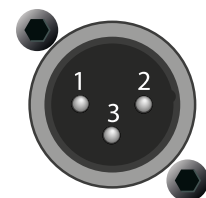

Through output

- Pin 1 - Ground
- Pin 2 - Signal (+)
- Pin 3 - Signal (-)
- Case - Earth (AC) ground and chassis

Audio signal can be daisy-chained using the through output connector on the input panel. A single source can drive multiple EX6 speakers with a paralleled input loop. If you are driving multiple EX6's make certain that the source device can drive the total load impedance presented by the paralleled input circuits.

The audio source must be capable of producing a minimum of 0 dB (0.775 V volts rms) to produce the maximum peak SPL over the operating bandwidth of the loudspeaker. To avoid distortion from the source, make sure the source equipment provides an adequate drive circuit design for the total paralleled load impedance presented by the speakers. The input impedance for a single loudspeaker is 20 k Ω . If "n" represents the number of EX6 loudspeakers in a system, paralleling the inputs of n loudspeakers will produce a balanced input load of 20 k Ω divided by "n".

If the loudspeaker produces noises such as hiss and popping, disconnect the audio cable from the loudspeaker, if the noise stops, then most likely the problem is not with the loudspeaker. Check the audio cable, source, and AC power for the source of the problem.

Ensure that all cabling carrying signal to multiple amplifiers and active speaker systems is wired correctly. Make sure that the polarity has not been reversed. Reversed polarity can cause severe degradation in frequency response and can also impact the dispersion characteristics of the speaker.

Power On / Signal LED

This LED turns green when the speaker is turned ON. The light will turn yellow when signal is present.

Low Cut Switch

The EX6 features a 90 Hz High Pass Filter. Pressing the button engages this filter allowing the speaker to reproduce frequencies only above 90Hz

Limiter

The EX6 employs a protection system based on rms limiting of the amplifiers. This type of protection strategy allows the speaker to operate safely under overload conditions. When the rms "limiter" engages, the output level of both amplifiers is reduced to a safe operating level. This type of protection allows the frequency response of the system to remain unchanged as the level is lowered. By not compressing or limiting peak signal, dynamics also remain unchanged. The control objective is to regulate the operating temperature of the transducers magnetic circuits long term. This ensures no impact on performance due to power compression and allows the components to retain their ability to reproduce high dynamics. When overdriven the rms limiter will disengage only if the input level is turned down.

Thermal protection

In the unlikely event of over heating the speaker system will shut down. You can expect for the system to be down for at least 2-3 minutes depending on the ambient temperature and whether the system is being exposed to direct sun light.

The EX6 features a fin-less heatsink that allows it to operate in any position. There is also an internal fan located inside the amplifier module. The fan speed is dependent on two factors; the temperature of the heat sink and the output level of the speaker. As temperature increases, so does fan speed. As audio level increases, fan speed also increases as a preventative measure designed to keep the heat sink temperature low. Under normal operating conditions, the fan noise remains inaudible. Please contact KV2 Audio or a local service representative should the system enter a thermal condition under normal operating conditions.

Transportation

To keep your EX6 speakers in optimum condition we recommend transportation in an optional KV2 Audio EX6 padded nylon cover (EX6CVR) or a professional road case.

Specifications

System Acoustic Performance

Max SPL Long-term	117 dB
Max SPL Peak	123 dB
-3 dB Response	68 Hz to 20 kHz
-10 dB Response	62 Hz to 28 kHz
Crossover Point	2.0 kHz

High Frequency Section

High Horn Coverage Horizontal / Vertical	100° x 100°
Throat Exit Diameter / Diaphragm Size	1" / 1.75"
Diaphragm Material	Nitride Titanium
Magnet Type	Neodymium

High Frequency Amplifier Specification

Type	Class AB Push-Pull
Rated Continuous Power	20 W
Distortion	<0.05%
Operating Bandwidth	2.0 kHz to 28 kHz

Low Frequency Section

Acoustic Design	Front Loaded, Bass Reflex
Woofer Size / Voice Coil Diameter / Design	6" / 1.75" / Trans Coil
Diaphragm Material	Epoxy Reinforced Cellulose
Magnet Type	Neodymium

Low Frequency Amplifier Specification

Type	High efficiency, Current-Enhancing, Switched-Rail Amplifier
Rated Continuous Power	180 W
Distortion	<0.05%
Operating Bandwidth	62 Hz to 2.0 kHz

Signal Input

Input Sensitivity	1 V RMS
Input Impedance	20 kΩ

Power

Power Connector	Neutrik PowerCon®
Operating Voltage Range	100 to 120 V @ 60Hz 230 to 250 V @ 50Hz
Recommended Amperage	2.5 A 115 V 1.25 A 230 V

Cabinet

Cabinet Material	Baltic birch
Handles	1
Pole Mount	Optional - Stand Adapter EX6
Color	"Orange peeled" Matt Black or any RAL

Physical Dimensions

Height	395 mm (15.55")
Width	220 mm (8.66")
Depth	274 mm (10.78")
Weight	12 kg (26.4 lb)

Frequency response

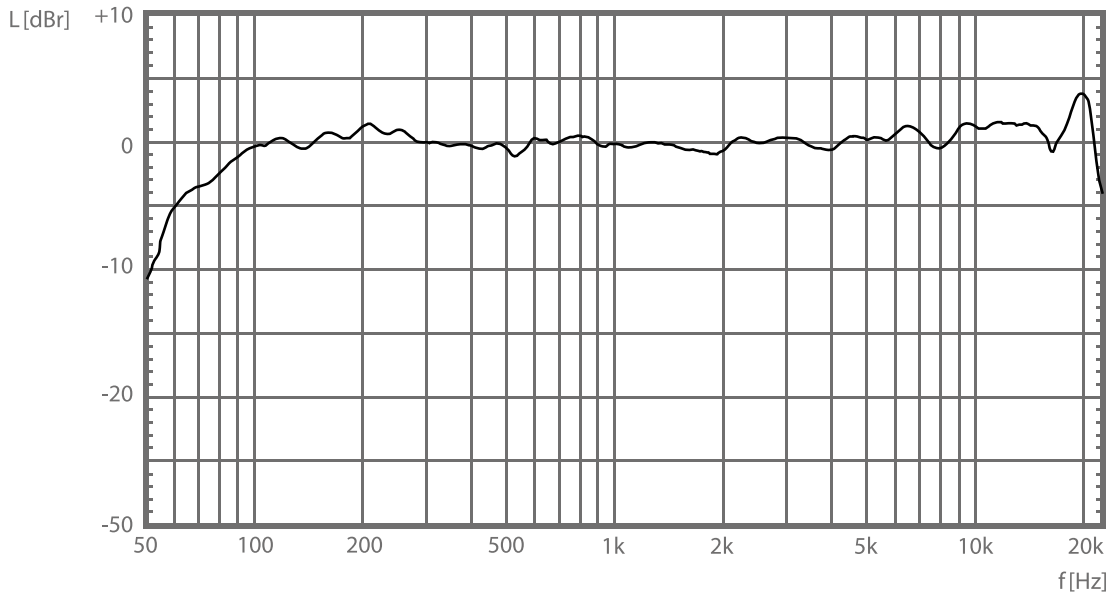

Horizontal Polarplots

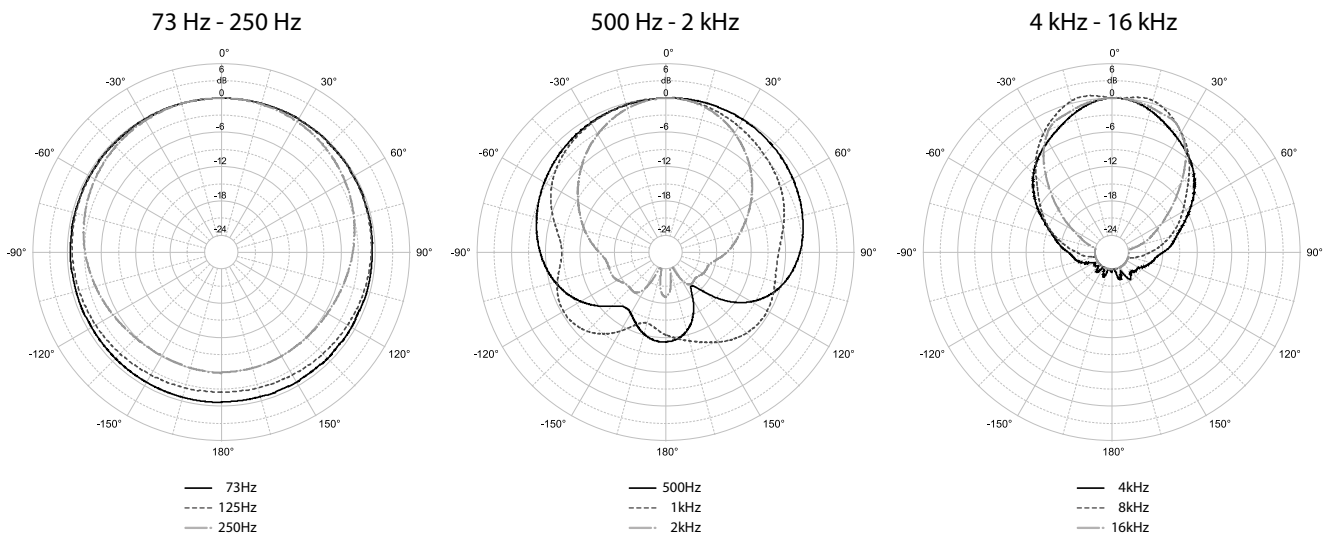

Vertical Polarplots

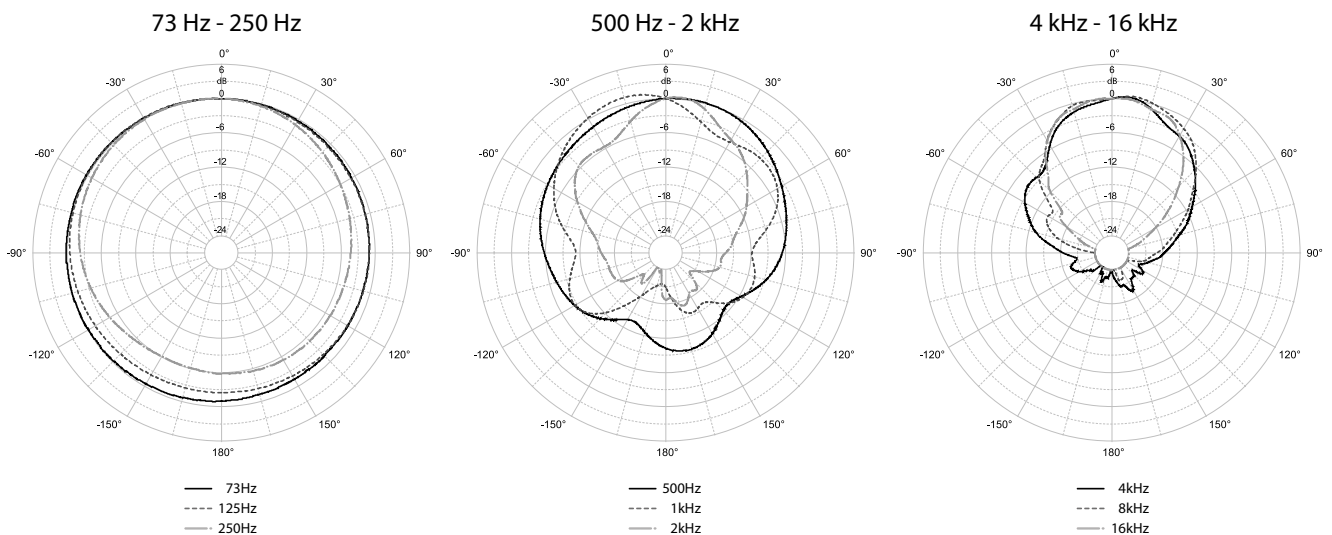

Using Multiple Boxes

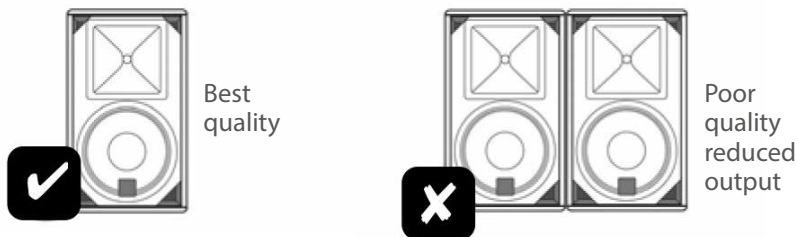

Fig. A

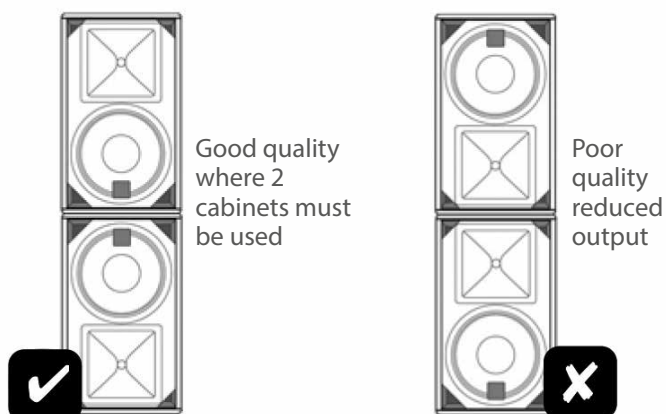

Fig. B



Fig. C

KV2 speakers are far more accurate, defined and phase coherent than virtually any other loudspeaker on the market. This very defined phase accuracy comes into play when trying to stack the speakers. It is very important not to use KV2 Audio Mid-High boxes directly side by side. (Fig. A) This will produce a poor quality sound cancelling out perfectly, which reduces overall output. Defined by the way our ears work, their position on our heads and the brain's understanding of the signals they produce, each ear will hear two sources in the horizontal plane very close together, but very slightly misaligned in arrival time. With our ears positioned on each side of our head, rather than on the top and bottom, they are very good at pinpointing precisely a sound in the Horizontal plane (i.e. it's exact position left to right in the sound field). Vertically (trying to pin point sound up and down) they are far less accurate and have a greater tolerance for error. Receiving multiple signals so phase coherent, but misaligned horizontally, leads the brain to get confused, which in turn leads it to interpret a confused poor quality, low intelligibility sound. KV2 exploits the additional vertical tolerance that the brain has by only stacking multiple cabinets vertically, as do modern Line arrays, but KV2 still keeps as close as possible to the theory of point source by using a maximum of two cabinets together, keeping the horns as far apart as possible. (Fig. B) This reduces the cancellations that most line arrays suffer from particularly in the high frequencies. The only exception to this maximum of two cabinets would be in a down fill / side fill application where an additional cabinet can be deployed but must be separated from the main forward firing system by an amount of degrees equivalent to the vertical or horizontal dispersion of that speaker. (Fig. C) Combining boxes and building systems in this way will give the maximum overall output, best audio quality and consistent, even coverage.

Drawings

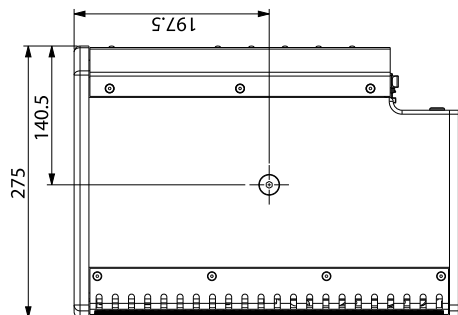
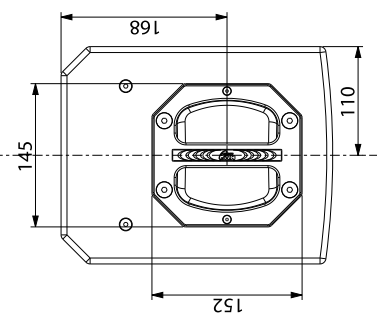
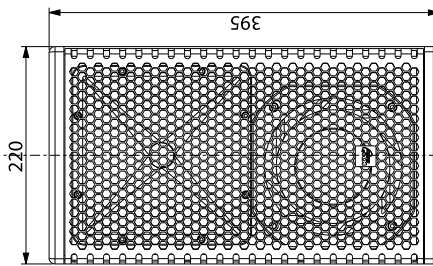
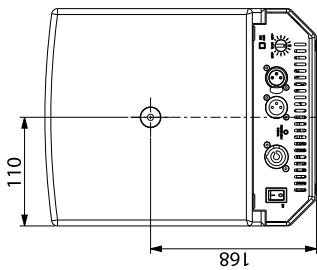
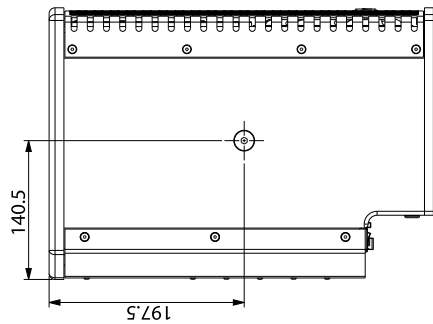
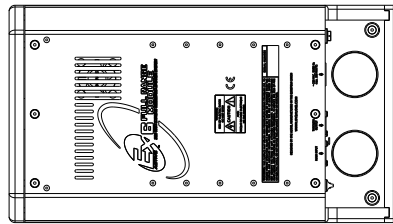
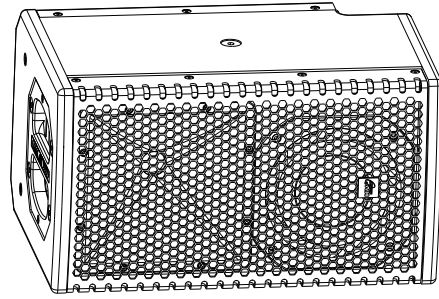

EX26 FULL RANGE MODULE

ACTIVE

350 WATT EXTREME RESOLUTION SPEAKER SYSTEM

EX26 - part number KVV 987 164 (230V)
KVV 987 165 (115V)



Application

Purposely designed as a stand-alone unit for extremely high quality vocal reproduction and output

- Church and houses of worship
- Conference and presentations
- Front of stage and balcony infill
- Full range portable PA when used with subwoofers for larger Multi-Media applications and small live music applications

Introduction

The EX26 is a 2-way high output, active, compact, Vocal speaker system. Design objectives for the EX26 were focused on the expansion of KV2 Audio's primary philosophy of speakers systems with increased dynamic range, very high output and a consistent sound character no matter what the output level. The EX26 sets new levels of performance for compact cabinets achieved through the integration of new amplifier, transducer and electronic control technologies that are closely tied to a passion for taking performance to the next level.

Electronics

Amplifier power, electronic crossovers, phase alignment, equalisation and speaker protection are integrated into the EX26's amplifier module.

The EX26's high frequency compression driver is powered and controlled by KV2 Audio's standard low intermodulation distortion, Class A/B, push-pull circuitry, designed to produce the lowest intermodulation distortion possible and the highest audio quality in the critical mid and high operating bands.

An improved version of KV2 Audio's current enhancing, bass driver switching amplifier has been developed for the EX26. The new configuration improves overall system efficiency and increases output allowing passive radiation of heat to take place through a unique "finless" heat sink that can be placed in any position or direction. Additionally, the EX26 amplifier unit contains an internally located electric fan that is operated by a temperature sensing circuit which will slowly bring the fan online as required.

Acoustic Components

The EX26's patent pending NVPD neodymium compression driver is loaded on a constant directivity horn designed for smooth, wide dispersion performance. More importantly, it has also been designed to precisely match the power response of the woofers at the crossover frequency, a crucial design objective that ensures smooth transition and minimizes anomalies.

The EX26 horn design is based on constant directivity geometry with an emphasis on generating very low air distortion artifacts, maintaining low transducer compression ratios, high output and wide dispersion (100° x 100°).

The horn is an injected molded aluminium part that functions as a heat dissipater for the compression driver's neodymium magnetic motor structure.

Enclosure Design

The EX26 is a very compact, asymmetrical geometry enclosure design allowing it to be used in a variety of applications.

A specially moulded aluminium handle was designed and fitted to the top of the cabinet. It functions as the principle pick up handle as well as providing several fixed installation and hanging solutions. It has a centrally located M10 hang point as well as four additional M6 bracket points found underneath the KV2 logo.

The device must only be operated when securely mounted.

AC Power Requirements

The EX26 is an advanced self-powered loudspeaker with on-board amplification and control systems. Understanding power distribution, voltage and current requirements, as well as electrical safety issues, is critical to the safe operation of the EX26.

AC Power

The EX26 uses a PowerCon 3-pole AC main system with locking connectors to prevent accidental disconnection. The main AC connector (blue) serves as the power input.

The EX26 operates in either 115 V or 230 V modes. Although pre-configured at the factory, the unit's operating voltage mode can be changed in the field.

Voltage Requirements

The EX26 operates safely and without audio discontinuity if the AC voltage stays within the operating window of 100 V–130 V in 115 V mode and 200 V–250 V when working in 230 V mode, at 50 or 60 Hz.

If the On LED does not illuminate or the system does not respond to audio input, remove AC power immediately. Verify that the voltage is within the proper range. If the problem persists, please contact KV2 Audio or an authorized service center.

If the voltage drops below the low boundary of its safe operating range, the loudspeaker will shut down if the voltage does not rise above the low boundary before storage circuits are depleted. How long the loudspeaker will continue to function during brownout depends on the amount of voltage drop and the audio source level during the drop. If the voltage increases above the upper boundary of the range, the power supply can be damaged.

It is recommended that the voltage supply be within the rated voltage window. This ensures that AC voltage variations from the service entry - or peak voltage drops due to cable runs - do not cause the amplifier to cycle on and off or cause damage to the power supply.

For best performance, the AC cable voltage drop should not exceed 10 volts, or 10 percent at 115 volts and 5 percent at 230 volts.

Make sure that even with the AC voltage drop, the AC voltage always stays within recommended operating ranges. The minimum electrical service amperage required by an EX26 speaker system is the sum of each loudspeaker's maximum continuous rms current. An additional 50 percent above that amperage is recommended to prevent peak voltage drops at the service entry.

The Power Connector

The EX26 requires a grounded outlet. It is very important that the loudspeaker AC supply be properly grounded in order to operate safely and properly. Use the PowerCon AC cable wiring diagram overleaf to create international or special-purpose power connectors:

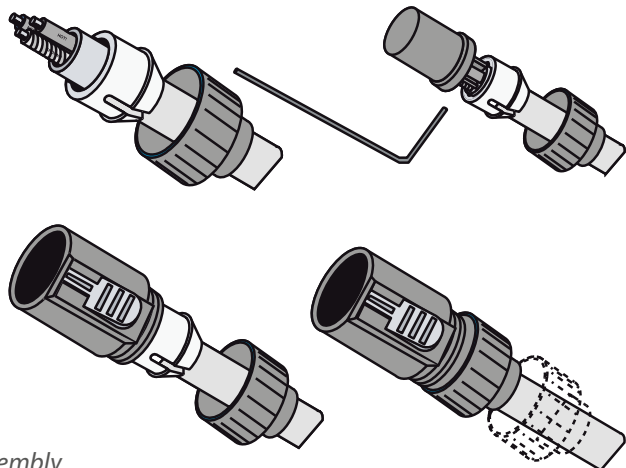

Power connector assembly

Current Requirements

Each EX26 requires approximately 4 Amps max at 115 V AC for proper operation. This allows up to three EX26's to be powered from one 15 A breaker at 115 V and up to seven EX26's at 230 V.

The EX26 presents a dynamic load to the AC mains, which causes the amount of current to fluctuate depending on quiet or loud operating levels. Since different cables and circuit breakers heat up at varying rates, it is essential to understand the types of current ratings and how they correspond to circuit breaker and cable specifications.

The maximum long-term continuous current is the maximum rms current during a period of at least ten seconds. It is used to calculate the temperature rise in cables, in order to select a cable size and gauge that conforms to electrical code standards. It is also used to select the rating for slow-reacting thermal breakers.

The burst current is the maximum rms current during a period of approximately one second, used to select the rating of most magnetic breakers and to calculate the peak voltage drop in long AC cables according to the formula:
 $V_{pk}(\text{drop}) = I_{pk} \times R(\text{cable total})$

The ultimate short-term peak current is used to select the rating of fast reacting magnetic breakers. Use the table below as a guide when selecting cable gauge size and circuit breaker ratings for your operating voltage.

Current Draw	115 V Mode	230 V Mode
Max Long Term Continuous	4 A rms	2 A rms
Burst Current	6 A rms	4 A rms
Short Term Peak	16 A peak	8 A peak

AC Cable Color Coding

If the colours referred to in the diagram don't correspond to the terminals in your plug, use the following guidelines: *Connect the blue wire to the terminal marked with a N or coloured black. Connect the brown wire to the terminal marked with a L or coloured red. Connect the green and yellow wire to the terminal marked with a E or coloured green or green and yellow.*

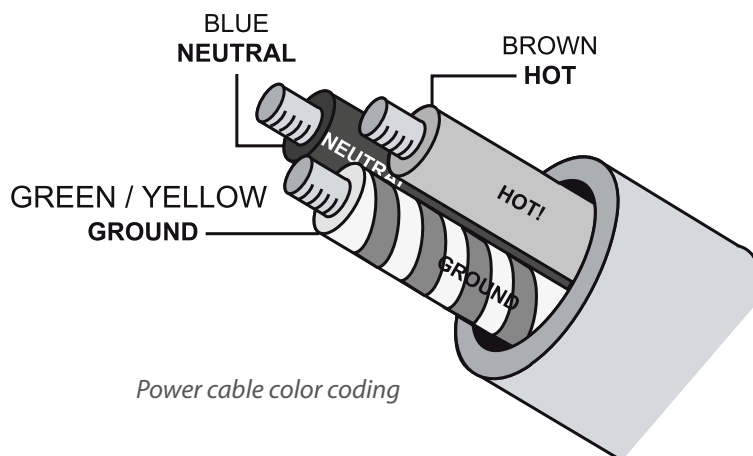

The EX26 requires a ground connection. Always use a grounded outlet and plug.

The EX26 Control Panel

The EX26 features an easy to use control panel featuring AC power in, audio input and through output, level control, LED status light and a High Pass filter.

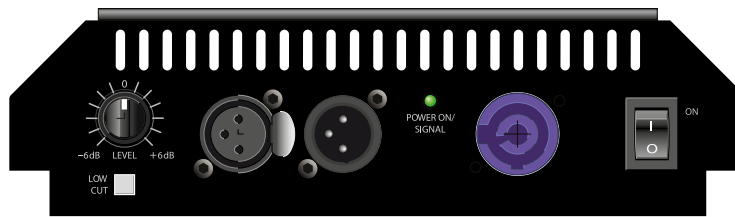

EX26 Rear panel

Audio Input and Output

The EX26 uses a balanced, female XLR connector for the audio input connector, and a male XLR connector to provide through output signal. The through output connector, wired in parallel to the audio input, will continue to provide the input signal if the EX26 is turned off. The audio input circuit presents a 20 kΩ balanced input impedance to a three-pin XLR connector with the following connections:



Main input

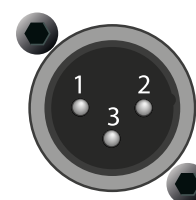

Through output

- Pin 1 - Ground
- Pin 2 - Signal (+)
- Pin 3 - Signal (-)
- Case - Earth (AC) ground and chassis

Audio signal can be daisy-chained using the through output connector on the input panel. A single source can drive multiple EX26 speakers with a paralleled input loop. If you are driving multiple EX26's make certain that the source device can drive the total load impedance presented by the paralleled input circuits.

The audio source must be capable of producing a minimum of 1.0V volts rms to produce the maximum peak SPL over the operating bandwidth of the loudspeaker. To avoid distortion from the source, make sure the source equipment provides an adequate drive circuit design for the total paralleled load impedance presented by the speakers. The input impedance for a single loudspeaker is 20 kΩ. If "n" represents the number of EX26 loudspeakers in a system, paralleling the inputs of n loudspeakers will produce a balanced input load of 20 kΩ divided by "n".

If the loudspeaker produces noises such as hiss and popping, disconnect the audio cable from the loudspeaker, if the noise stops, then most likely the problem is not with the loudspeaker. Check the audio cable, source, and AC power for the source of the problem.

Ensure that all cabling carrying signal to multiple amplifiers and active speaker systems is wired correctly. Make sure that the polarity has not been reversed. Reversed polarity can cause severe degradation in frequency response and can also impact the dispersion characteristics of the speaker.

Important information!

Please be aware and notified that this product – **EX26** with a designated '**P**' Serial Number onwards now comes with a modified Polarity that will appear reversed when compared to older existing versions of this model – EX26. This has been done to ensure that when used with other EX models within the range, there will not be any difference in polarity response between models.

If you have existing EX26 models with a Serial Number that has a letter preface prior to the '**P**' designation, applying a simple reversed XLR connector input lead crossing pins 2 & 3 at one side will correct this when in use.

Power On / Signal LED

This LED turns green when the speaker is turned ON. The light will turn yellow when signal is present.

Low Cut Switch

The EX26 features a 90 Hz High Pass Filter. Pressing the button engages this filter allowing the speaker to reproduce frequencies only above 90 Hz.

Limiter

The EX26 employs a protection system based on rms limiting of the amplifiers. This type of protection strategy allows the speaker to operate safely under overload conditions. When the rms "limiter" engages, the output level of both amplifiers is reduced to a safe operating level. This type of protection allows the frequency response of the system to remain unchanged as the level is lowered. By not compressing or limiting peak signal, dynamics also remain unchanged. The control objective is to regulate the operating temperature of the transducers magnetic circuits long term. This ensures no impact on performance due to power compression and allows the components to retain their ability to reproduce high dynamics. When overdriven the rms limiter will disengage only if the input level is turned down.

Thermal Protection

In the unlikely event of over heating the speaker system will shut down. You can expect for the system to be down for at least 2-3 minutes depending on the ambient temperature and whether the system is being exposed to direct sun light.

The EX26 features a fin-less heatsink that allows it to operate in any position. There is also an internal fan located inside the amplifier module. The fan speed is dependent on two factors; the temperature of the heat sink and the output level of the speaker. As temperature increases, so does fan speed. As audio level increases, fan speed also increases as a preventative measure designed to keep the heat sink temperature low. Under normal operating conditions, the fan noise remains inaudible. Please contact KV2 Audio or a local service representative should the system enter a thermal condition under normal operating conditions.

Transportation

To keep your EX26 speakers in optimum condition we recommend transportation in an optional KV2 Audio EX26 padded nylon cover (EX26CVR) or a professional road case.

Specifications

System Acoustic Performance

Max SPL Long-term	124 dB
Max SPL Peak	130 dB
-3 dB Response	80 Hz to 20 kHz
-10 dB Response	65 Hz to 28 kHz
Crossover Point	2.5 kHz

High Frequency Section

Acoustic Design	Horn Loaded
High Horn Coverage Horizontal / Vertical	100° x 100°
Throat Exit Diameter / Diaphragm Size	1" / 1.75"
Diaphragm Material	Nitride Titanium
Magnet Type	Neodymium

High Frequency Amplifier Specification

Type	Class AB Push-Pull
Rated Continuous Power	20 W
Distortion	<0.05%
Operating Bandwidth	2.5 kHz to 28 kHz

Low Frequency Section

Acoustic Design	Front Loaded, Bass Reflex
Woofer Size / Voice Coil Diameter	6" / 1.75"
Magnet Type	Neodymium
Diaphragm Material	Epoxy Reinforced Cellulose

Low Frequency Amplifier Specification

Type	High efficiency, Current-Enhancing, Switched-Rail Amplifier
Rated Continuous Power	350 W
Distortion	<0.05%
Operating Bandwidth	68 Hz to 2.5 kHz

Signal Input

Input Sensitivity	1.0 V RMS
Input Impedance	20 kΩ

Power

Power Connector	Neutrik PowerCon®
Operating Voltage Range	100 to 120 V @ 60 Hz 230 to 250 V @ 50 Hz
Recommended Amperage	3.15 A 115 V 1.6 A 230 V

Cabinet

Cabinet Material	Baltic birch
Handles	1
Pole Mount	35 mm
Color	"Orange peeled" Matt Black or any RAL

Physical Dimensions

Height	570 mm (22.44")
Width	220 mm (8.66")
Depth	274 mm (10.78")
Weight	16.5 kg (36.4 lb)

Frequency response

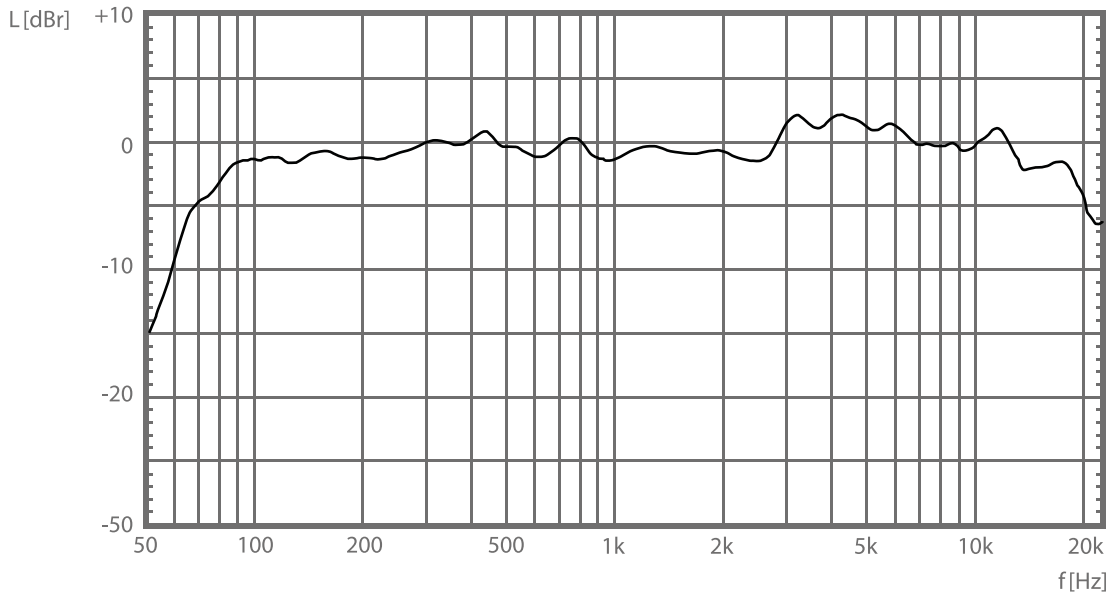

Horizontal Polarplots

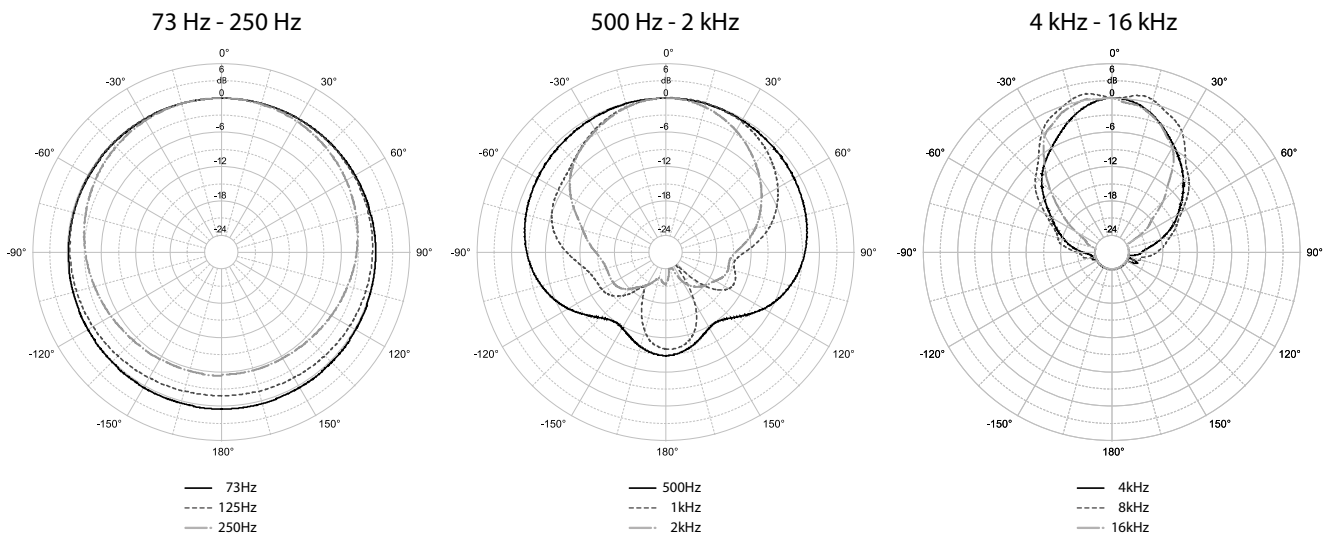

Vertical Polarplots

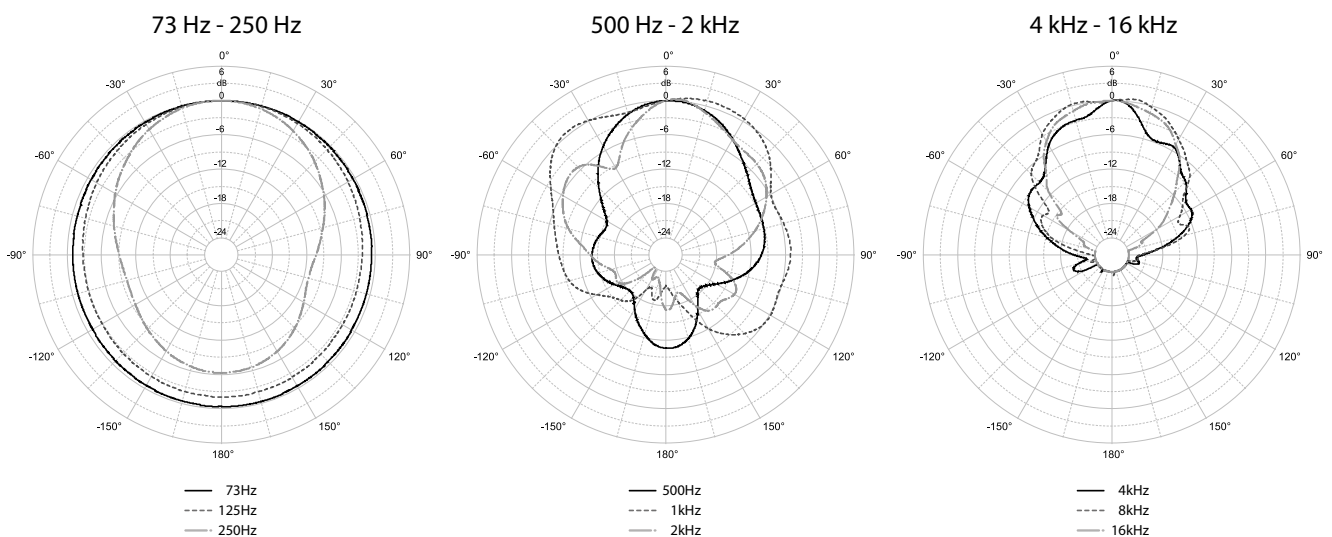

Using Multiple Boxes

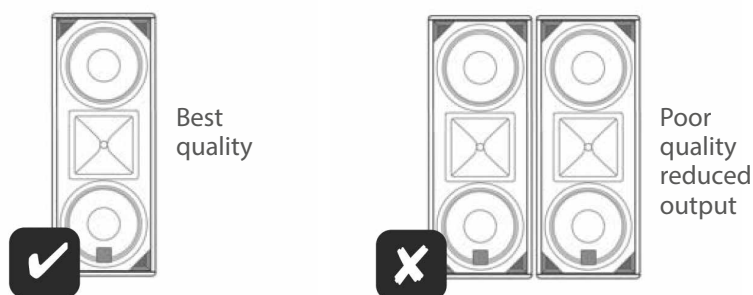
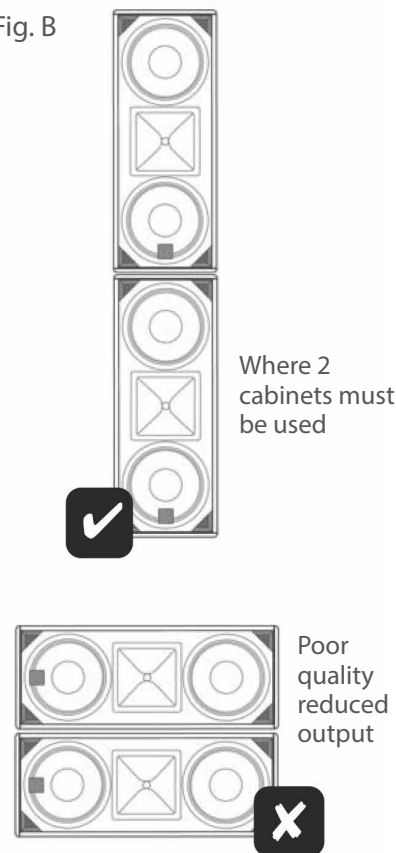

Fig. A



Fig. C

Fig. B



KV2 speakers are far more accurate, defined and phase coherent than virtually any other loudspeaker on the market. This very defined phase accuracy comes into play when trying to stack the speakers.

It is very important not to use KV2 Audio Mid-High boxes directly side by side. (Fig. A) This will produce a poor quality sound cancelling out perfectly, which reduces overall output. Defined by the way our ears work, their position on our heads and the brain's understanding of the signals they produce, each ear will hear two sources in the horizontal plane very close together, but very slightly misaligned in arrival time.

With our ears positioned on each side of our head, rather than on the top and bottom, they are very good at pinpointing precisely a sound in the Horizontal plane (i.e. it's exact position left to right in the sound field). Vertically (trying to pin point sound up and down) they are far less accurate and have a greater tolerance for error. Receiving multiple signals so phase coherent, but misaligned horizontally, leads the brain to get confused, which in turn leads it to interpret a confused poor quality, low intelligibility sound.

KV2 exploits the additional vertical tolerance that the brain has by only stacking multiple cabinets vertically, as do modern Line arrays, but KV2 still keeps as close as possible to the theory of point source by using a maximum of two cabinets together, keeping the horns as far apart as possible. (Fig. B) This reduces the cancellations that most line arrays suffer from particularly in the high frequencies. The only exception to this maximum of two cabinets would be in a down fill / side fill application where an additional cabinet can be deployed but must be separated from the main forward firing system by an amount of degrees equivalent to the vertical or horizontal dispersion of that speaker. (Fig. C) Combining boxes and building systems in this way will give the maximum overall output, best audio quality and consistent, even coverage.

Drawings

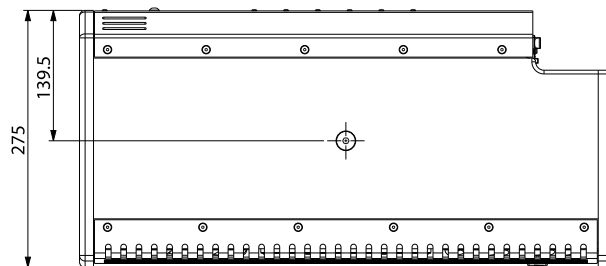
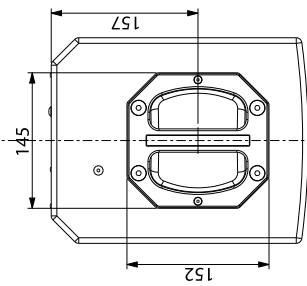
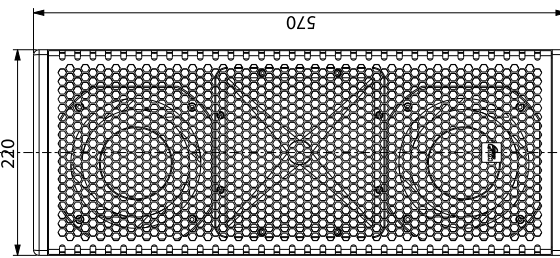
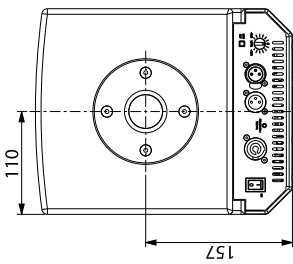
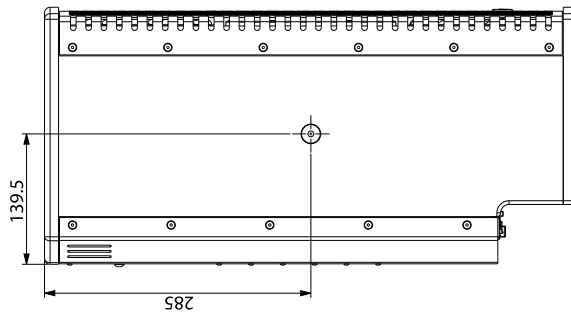
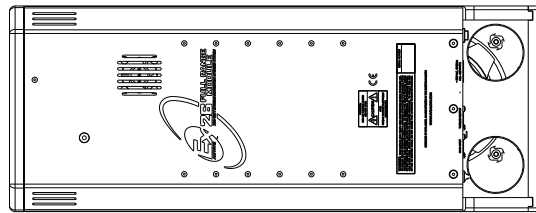
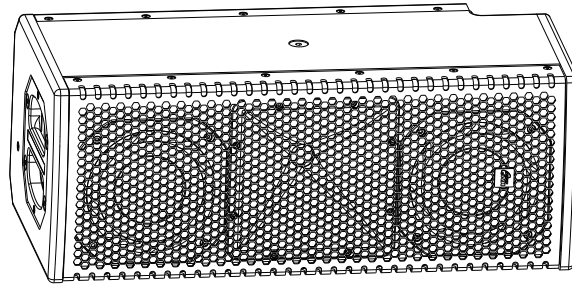

EX10 FULL RANGE MODULE

ACTIVE

500 WATT EXTREME RESOLUTION SPEAKER SYSTEM

EX10 - part number KVV 987 097 (250V)
KVV 987 011 (230V)
KVV 987 012 (115V)



Application

Specifically designed for high quality, high output multi-tasking, portable music playback and live performance in small applications

- Full range stand-alone solution or scalable to larger capabilities with subwoofers for large conference, meetings and small to medium performance venues
- Multi-purpose fixed installations
- Personal monitoring
- Infill for larger main KV2 Audio systems

Introduction

The EX10 is a 2-way high output, active, compact, full-range speaker system. Design objectives for the EX10 were focused on the expansion of KV2 Audio's primary philosophy of speakers systems with increased dynamic range, very high output and a consistent sound character no matter what the output level. The EX10 sets new levels of performance for compact cabinets achieved through the integration of new amplifier, transducer and electronic control technologies that are closely tied to a passion for taking performance to the next level.

Electronics

Amplifier power, electronic crossovers, phase alignment, equalization, time correction and speaker protection are integrated into the EX10's amplifier module. On-board electronics ensures fast, easy set up and complete control. An improved version of KV2 Audio's switch mode, current enhancing low frequency amplifier has been developed for the EX10. The new configuration improves overall system efficiency and increases output, allowing passive radiation of heat to take place through a unique "fin-less" heat sink that can be placed in any position or direction. This ensures cool operation in horizontal or vertical applications. Additionally, the EX10 amplifier unit contains an internally located electric fan that is operated by a temperature sensing circuit which will slowly bring the fan online as required in extreme, high temperature situations.

Months of research were invested into designing circuitry that ensures that the extreme dynamic range exemplified by the speaker system is maintained even under clipping conditions. The real test of the EX10's limits is when it is exposed to the rigors and demands of live audio playback where consistent clipping of amplifiers, generation of distortion artifacts, dramatic increases in the floor and the elimination of dynamic range put the product to an extreme test.

The EX10's high frequency compression driver is powered and controlled by KV2 Audio's standard low intermodulation distortion, Class A/B, push-pull circuitry, high and mid frequency amplifier design. Metal Oxide Silicon Field Effect Transistors (MOSFET) are used for the output stage and the compression driver coupled through a transformer balanced speaker output. The entire performance strategy for this type of design is based on producing the lowest intermodulation distortion possible and the highest audio quality in the critical mid and high operating bands.

Acoustic Components

KV2 Audio has developed a revolutionary woofer technology called Trans-Coil™. The woofer has two coils, a standard voice coil assembly and a second coil placed directly on the neodymium magnetic circuit's pole piece. This technology eliminates voice coil inductance resulting in a flat impedance response above the resonance point and achieves faster transient response through increased force and control of the moving mass. It also linearises acoustic and electrical phase response, reduces harmonic distortion and increases power transfer and transducer speed. Through this technology, the speaker now behaves like both a woofer at lower frequencies and like a mid-range at higher frequencies allowing a seamless transition to take place at the crossover frequency.

The EX10's patent pending neodymium compression driver is loaded on a constant directivity horn designed for smooth, wide dispersion performance. More importantly, it has also been designed to precisely match the power response of the woofer at the crossover frequency, a crucial design objective that ensures smooth transition and minimizes anomalies.

The compression driver is a new, patent pending 1.75- inch titanium diaphragm design, featuring a complex geometry phase plug that dramatically lowers distortion, eliminates ring modes and provides clearer, ripple free performance.

The EX10 horn was designed with two primary performance goals. The mechanical design allows the horn to be rotated 90 degrees, allowing for complete flexibility in selection of vertical and horizontal system set up. The horn design is based on constant- directivity geometry with an emphasis on generating very low air distortion artifacts, maintaining low transducer compression ratios, high output and wide dispersion (100 x 80). The horn is an injected molded aluminum part that functions as a heat dissipater for the compression driver's neodymium magnetic motor structure.

Enclosure Design

The EX10 is a very compact, asymmetrical geometry enclosure design allowing it to be used in a variety of applications and featuring a number of ergonomically designed components that make it lightweight and easy to use. An extensive set of professional hardware features enables the EX10 to be used in a variety of environments using an array of industry standard hardware. These facilitate both portable and fixed installations with a maximum amount of mounting flexibility.

A specially molded aluminum top handle was designed and fitted to the top of the cabinet. It functions as the principle pick up handle as well as providing several fixed installation and hanging solutions. It has a centrally located M10 hang point as well as four additional M6 bracket points. The handles four principal mounting bolts also provide an Omnimount™ bracket point. There are two side-mounted M10 hang points that can be used with brackets or eyebolts.

AC Power

The EX10 uses a PowerCon 3-pole AC main system with locking connectors to prevent accidental disconnection. The main AC connector (blue) serves as the power input.

The EX10 operates in either 115 V, 230 V or 250 V modes. Although pre-configured at the factory, the unit's operating voltage mode can be changed in the field.

Voltage Requirements

The EX10 operates safely and without audio discontinuity if the AC voltage stays within the operating window of 100 V-120 V in 115 V mode, 205 V-240 V in 230 V mode and 225 V-260 V when working in 250 V mode, at 50 or 60 Hz.

If the On LED does not illuminate or the system does not respond to audio input, remove AC power immediately. Verify that the voltage is within the proper range. If the problem persists, please contact KV2 Audio or an authorized service center.

If the voltage drops below the low boundary of its safe operating range, the loudspeaker will shut down if the voltage does not rise above the low boundary before storage circuits are depleted. How long the loudspeaker will continue to function during brownout depends on the amount of voltage drop and the audio source level during the drop.

If the voltage increases above the upper boundary of the range, the power supply can be damaged.

It is recommended that the voltage supply be within the rated voltage window. This ensures that AC voltage variations from the service entry- or peak voltage drops due to cable runs do not cause the amplifier to cycle on and off or cause damage to the power supply.

For best performance, the AC cable voltage drop should not exceed 10 volts, or 10 percent at 115 volts and 5 percent at 230 volts.

Make sure that even with the AC voltage drop, the AC voltage always stays within recommended operating ranges. The minimum electrical service amperage required by a EX10 speaker system is the sum of each loudspeaker's maximum continuous rms current. An additional 50 percent above the minimum amperage is recommended to prevent peak volt-age drops at the service entry.

The Power Connector

The EX10 requires a grounded outlet. It is very important that the loudspeaker AC supply be properly grounded in order to operate safely and properly. Use the PowerCon AC cable-wiring diagram on page 27 to create international or special-purpose power connectors:

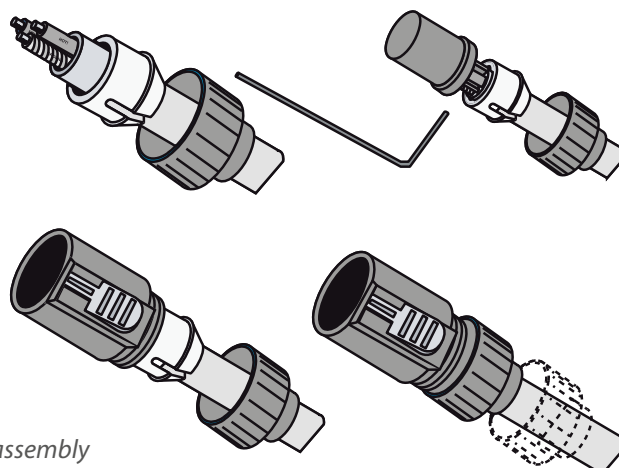

Power connector assembly

Current Requirements

Each EX10 requires approximately 5 Amps max at 115 V AC for proper operation. This allows up to three EX10's to be powered from one 15 A breaker at 115 V and up to 6 loudspeakers at 230 V or 250 V.

The EX10 presents a dynamic load to the AC mains, which causes the amount of current to fluctuate depending on quiet or loud operating levels. Since different cables and circuit breakers heat up at varying rates, it is essential to understand the types of current ratings and how they correspond to circuit breaker and cable specifications.

The maximum long-term continuous current is the maximum rms current during a period of at least ten seconds. It is used to calculate the temperature rise in cables, in order to select a cable size and gauge that conforms to electrical code standards. It is also used to select the rating for slow-reacting thermal breakers.

The burst current is the maximum rms current during a period of approximately one second, used to select the rating of most magnetic breakers and to calculate the peak voltage drop in long AC cables according to the formula:
 $V_{pk}(\text{drop}) = I_{pk} \times R(\text{cable total})$

The ultimate short-term peak current is used to select the rating of fast reacting magnetic breakers. Use the table below as a guide when selecting cable gauge size and circuit breaker ratings for your operating voltage.

Current Draw	115 V Mode	230 V, 250 V
Max Long Term Continuous	5 A rms	2.5 A rms
Burst Current	7.5 A rms	5 A rms
Short Term Peak	20 A peak	10 A peak

AC Cable Color Coding

If the colors referred to in the diagram don't correspond to the terminals in your plug, use the following guidelines:
 Connect the blue wire to the terminal marked with a N or colored black. Connect the brown wire to the terminal marked with a L or colored red. Connect the green and yellow wire to the terminal marked with a E or colored green or green and yellow.

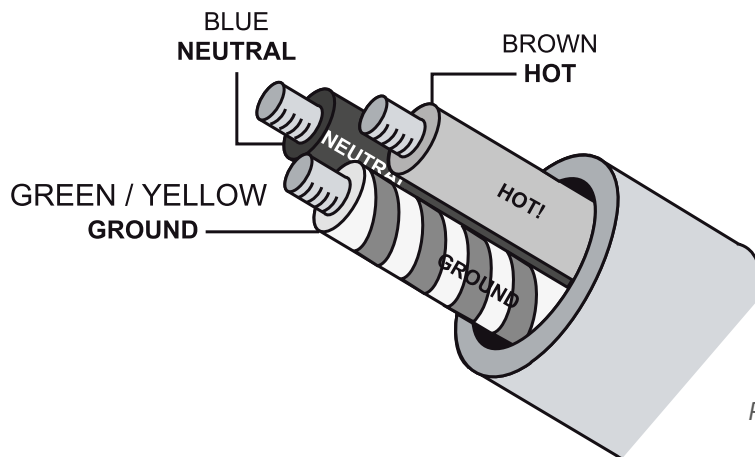

Power cable color coding

The EX10 requires a ground connection. Always use a grounded outlet and plug.

The EX10 Control Panel

The EX10 features an easy to use rear control panel with audio input and output, level control, LED status lights and a low pass filter that can be engaged when the loudspeaker is used as a stage monitoring device.

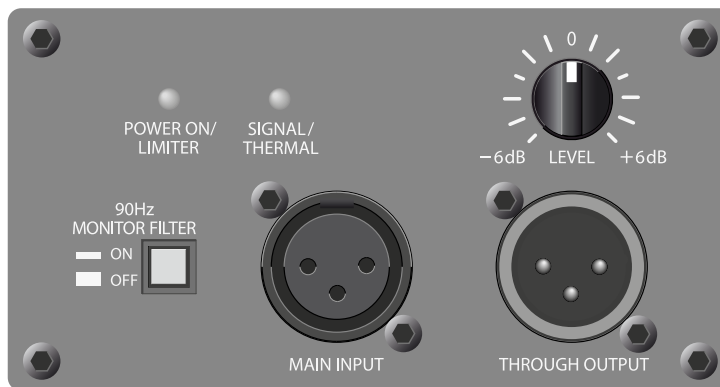

EX10 Rear panel

Audio Input and Output

The EX10 uses a balanced, female XLR connector for the audio input connector, and a male XLR connector to provide through output signal. The through output connector, wired in parallel to the audio input, will continue to provide the input signal if the EX10 is turned off. The audio input circuit presents a 20 kOhm balanced input impedance to a three-pin XLR connector with the following connectors:



Main input

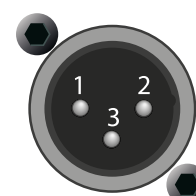

Through output

- Pin 1 - Ground
- Pin 2 - Signal (+)
- Pin 3 - Signal (-)
- Case - Earth (AC) ground and chassis

Audio signal can be daisy-chained using the through output connector on the input panel. A single source can drive multiple EX10 speakers with a paralleled input loop. If you are driving multiple EX10's in an array, make certain that the source device can drive the total load impedance presented by the paralleled input circuit of the array. The audio source must be capable of producing a minimum of 20 dB volts (10 volts rms into 600 ohms) to produce the maximum peak SPL over the operating bandwidth of the loudspeaker. To avoid distortion from the source, make sure the source equipment provides an adequate drive circuit design for the total paralleled load impedance presented by the array. The input impedance for a single loudspeaker is 20 kOhms. If "n" represents the number of EX10 loudspeakers in a system, paralleling the inputs of n loudspeakers will produce a balanced input load of 20 kOhms divided by "n".

Most source equipment is safe for driving loads no smaller than 10 times the source's output impedance. For example, cascading an array of 10 units consisting of EX10 speakers produces an input impedance of 2000 ohms (20kOhms divided by 10). The source equipment should have an output impedance of 200 Ohms or less. This is also true when connecting EX10's in parallel (loop out) with other KV2 Audio amplifiers and active speakers and subwoofers.

If the loudspeaker produces noises such as hiss and popping, disconnect the audio cable from the loudspeaker, if the noise stops, then most likely the problem is not with the loudspeaker. Check the audio cable, source, and AC power for the source of the problem.

Ensure that all cabling carrying signal to multiple amplifiers and active speaker systems is wired correctly. Make sure that the polarity has not been reversed. Reversed polarity can cause severe degradation in frequency response and can also impact the dispersion characteristics of the speaker.

Amplifiers and Acoustic Filters

The EX10 is powered by two separate power amplifiers specifically designed and optimized for the low frequency and high frequency drivers. The control system in the EX10 processes the audio signal through a series of electronic filters and circuits providing equalization, crossover filters, phase adjustment, thermal and overdrive protection.

The EX10 employs a protection system based on rms limiting of the amplifiers. This type of protection strategy allows the speaker to operate safely under overload conditions. When the rms "limiter" engages, the output level of both amplifiers is reduced to a safe operating level. This type of protection allows the phase response of the system to remain unchanged as the level is lowered. By not compressing or limiting peak signal, dynamics also remain unchanged. The control objective is to regulate the operating temperature of the transducers magnetic circuits long term. This ensures no impact on performance due to power compression and allows the components to retain their ability to reproduce high dynamics.

LED Status Lights

The EX10 control panel uses two distinct LED's to provide operating status information.

Power On / Limiter LED

This LED turns green when the speaker is turned ON. The light will continue to be green during normal operation of the speaker system. Should the rms limiting system be engaged due to overdriving of the EX10, the LED will change color from green to yellow. The audible effect of the rms limiter is a lowering of overall output level. The rms limiter will disengage only if the input level is turned down..

Signal / Thermal LED

This LED turns green when there is audio signal present in the EX10. This signal indicator can be used to troubleshoot wiring problems. The LED will change from green to yellow under a thermal condition resulting from overheating of the amplifier system. Under this condition, the speaker system will shut down. You can expect for the system to be down for at least 2-3 minutes depending the ambient temperature and whether the system is being exposed to direct sun light.

The EX10 features a finless heatsink that allows it to operate in any position. There is also an internal fan located inside the amplifier module. The fan speed is dependent on two factors; the temperature of the heat sink and the output level of the speaker. As temperature increases, so does fan speed. As audio level increases, fan speed also increases as a preventative measure designed to keep the heat sink temperature low. Under normal operating conditions, the fan noise remains inaudible. Please contact KV2 Audio or a local service representative should the system enter a thermal condition under normal operating conditions.

Stage Monitor Filter

The EX10 features a 90 Hz Monitor Filter control. Depressing the button engages a low pass audio filter allowing the speaker to be effectively used to reproduce frequencies above 90Hz.

When using EX10 as a stage monitor, the horn should be rotated 90°.

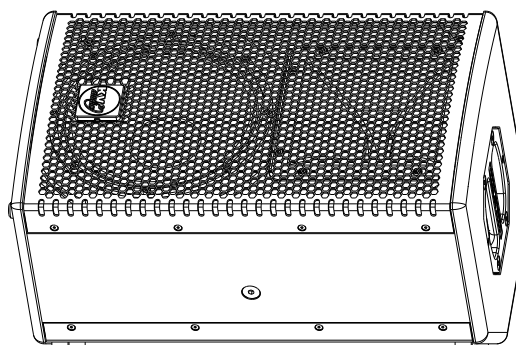

Specifications

System Acoustic Performance

Max SPL Long-term	126 dB
Max SPL Peak	132 dB
-3 dB Response	68 Hz to 20 kHz
-10 dB Response	55 Hz to 28 kHz
Crossover Point	1.6 kHz

High Frequency Section

Acoustic Design	Horn Loaded
High Horn Coverage Horizontal / Vertical	100° x 80°
Rotatable Horn	YES
Throat Exit Diameter / Diaphragm Size	1" / 1.75"
Diaphragm Material	Titanium
Magnet Type	Neodymium

High Frequency Amplifier Specification

Type	Class AB Push-Pull
Rated Continuous Power	50 W
Distortion	<0.05%
Operating Bandwidth	1.6 kHz to 28 kHz

Low Frequency Section

Acoustic Design	Front Loaded, Bass Reflex
Woofer Size / Voice Coil Diameter / Design	10" / 2.5" / Trans Coil
Diaphragm Material	Epoxy Reinforced Cellulose
Magnet Type	Neodymium

Low Frequency Amplifier Specification

Type	High efficiency, Current-Enhancing, Switched-Rail Amplifier
Rated Continuous Power	450 W
Distortion	<0.05%
Operating Bandwidth	55 Hz to 1.6 kHz

Signal Input

Input Sensitivity	0.775 V RMS
Input Impedance	20 kΩ

Power

Power Connector	Neutrik PowerCon®
Operating Voltage Range	100 to 120 V @ 60 Hz 205 to 240 V @ 50 Hz 225 to 260 V @ 50 Hz
Recommended Amperage	6 A 115 V 3 A 230 V 3 A 250 V

Cabinet

Cabinet Material	Baltic birch
Handles	1
Pole Mount	35 mm
Color	"Orange peeled" Matt Black or any RAL

Physical Dimensions

Height	514 mm (20.23")
Width	310 mm (12.20")
Depth	326 mm (12.83")
Weight	20.5 kg (45.2 lb)

Frequency response

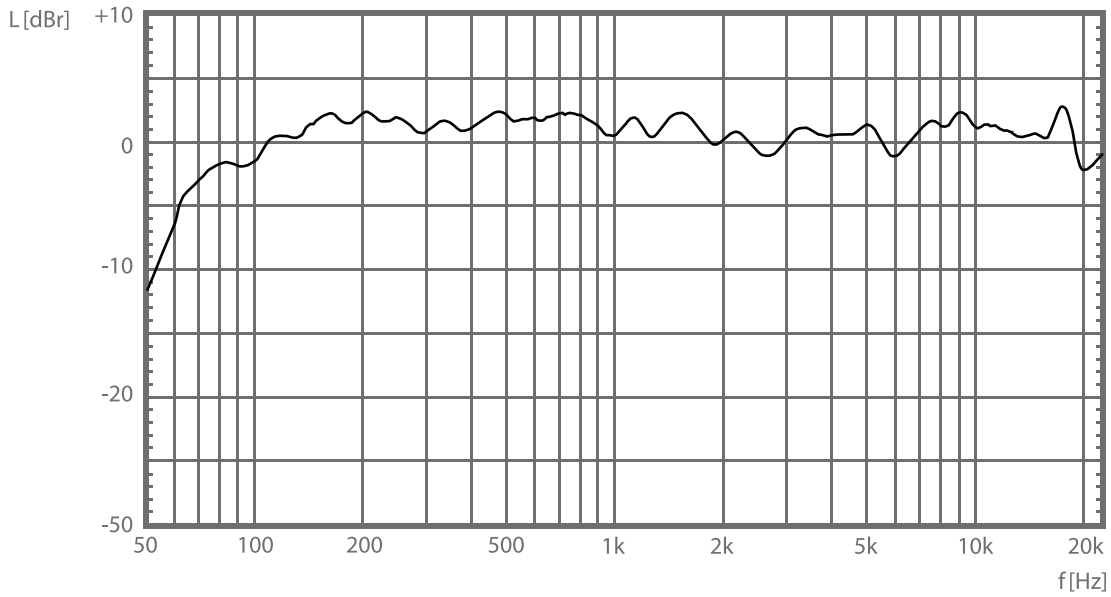

Horizontal Polarplots

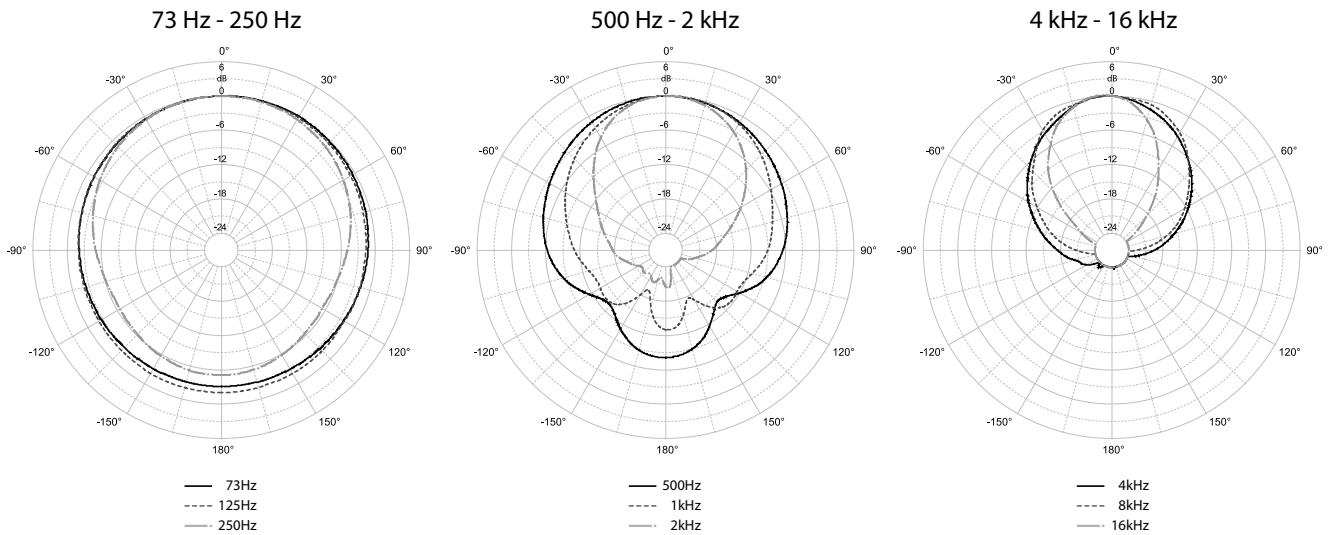

Vertical Polarplots

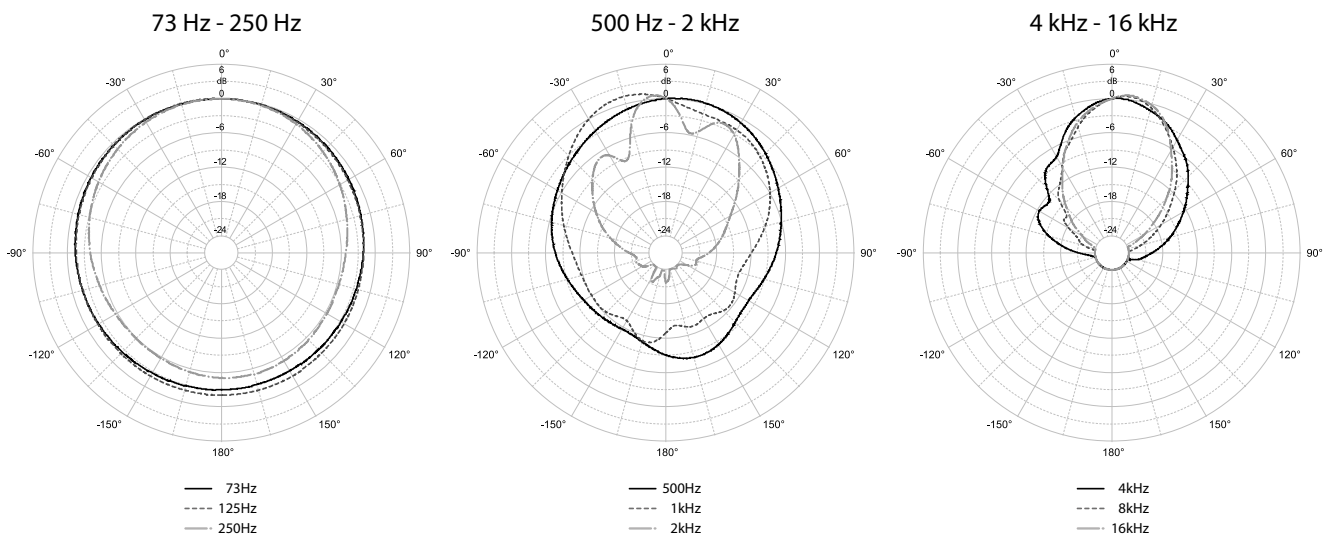

Drawings

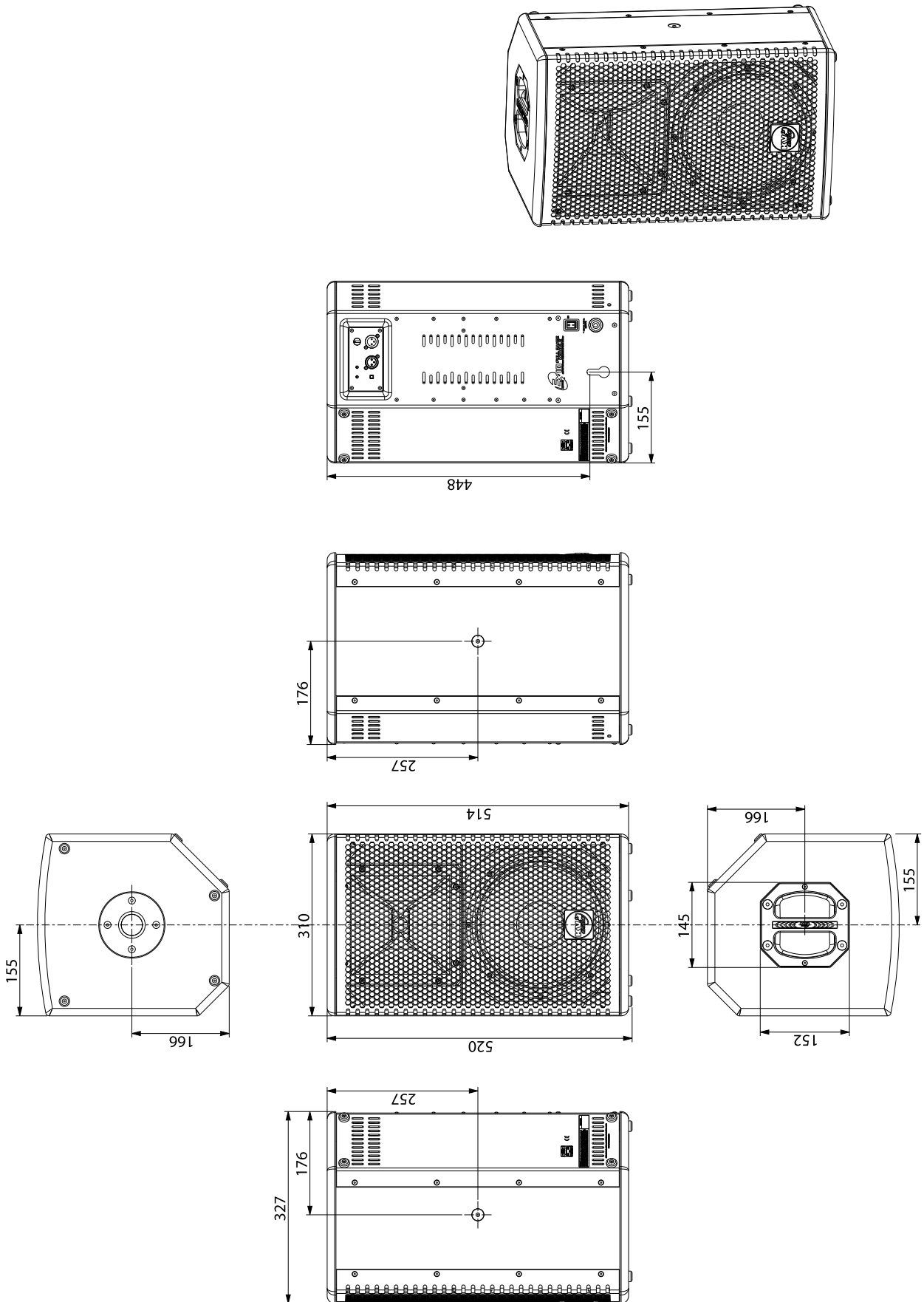

EX28 FULL RANGE MODULE

ACTIVE

500 WATT EXTREME RESOLUTION SPEAKER SYSTEM

EX28 - part number **KVV 987 462 (250V)**
KVV 987 461 (230V)
KVV 987 460 (115V)



Application

Purposely designed as a stand-alone unit for extremely high quality vocal reproduction and output

- Theatres, Churches and houses of worship
- Conference and presentations
- Front of stage and balcony infill
- Full range portable PA when used with subwoofers for larger Multi-Media applications and small live music applications

Introduction

The EX28 is a 2.5-way full-range active loudspeaker system that builds on the success of the EX26 whilst adding further low frequency extension. Its compact profile makes it ideal for a multitude of FOH and infill applications in Theatres, Leisure venues, Houses of Worship and Concert Halls, where the ultimate quality from a discreet loudspeaker solution is required. Two individually designed 8" neodymium mid - bass woofers are utilised for extended low frequency performance, whilst one unit incorporates KV2 Audio SLA Transcoil technology for improved vocal performance, along with a neodymium compression driver mounted on a 100° by 80° horn.

Electronics

Amplifier power, electronic crossovers, phase alignment, equalisation and speaker protection are integrated into the EX28's amplifier module.

The EX28's high frequency compression driver is powered and controlled by KV2 Audio's standard low intermodulation distortion, Class A/B, push-pull circuitry, designed to produce the lowest intermodulation distortion possible and the highest audio quality in the critical mid and high operating bands.

An improved version of KV2 Audio's current enhancing, bass driver switching amplifier has been developed for the EX28. The new configuration improves overall system efficiency and increases output allowing passive radiation of heat to take place through a unique "fin-less" heat sink that can be placed in any position or direction. Additionally, the EX28 amplifier unit contains an internally located electric fan that is operated by a temperature sensing circuit which will slowly bring the fan on-line as required.

Acoustic Components

The EX28's NVPD neodymium compression driver is loaded on a constant directivity horn designed for smooth, wide dispersion performance. More importantly, it has also been designed to precisely match the power response of the woofers at the crossover frequency, a crucial design objective that ensures smooth transition and minimizes anomalies.

The EX28 horn design is based on constant directivity geometry with an emphasis on generating very low air distortion artifacts, maintaining low transducer compression ratios, high output and wide dispersion (100° x 80°).

The horn is an injected molded aluminium part that functions as a heat dissipater for the compression driver's neodymium magnetic motor structure.

Enclosure Design

The EX28 is a very compact, asymmetrical geometry enclosure design allowing it to be used in a variety of applications.

A specially moulded aluminium handle was designed and fitted to the top of the cabinet. It functions as the principle pick up handle as well as providing fixed installation and hanging solutions. It has a centrally located M10 hang point.

AC Power Requirements

The EX28 is an advanced self-powered loudspeaker with on-board amplification and control systems. Understanding power distribution, voltage and current requirements, as well as electrical safety issues, is critical to the safe operation of the EX28.

AC Power

The EX28 uses a PowerCon 3-pole AC main system with locking connectors to prevent accidental disconnection. The main AC connector (blue) serves as the power input.

The EX28 operates in either 115 V or 230 V modes. Although pre-configured at the factory, the unit's operating voltage mode can be changed in the field.

Voltage Requirements

The EX28 operates safely and without audio discontinuity if the AC voltage stays within the operating window of 100 V-130 V in 115 V mode and 200 V-250 V when working in 230 V mode, at 50 or 60 Hz.

If the On LED does not illuminate or the system does not respond to audio input, remove AC power immediately. Verify that the voltage is within the proper range. If the problem persists, please contact KV2 Audio or an authorized service center.

If the voltage drops below the low boundary of its safe operating range, the loudspeaker will shut down if the voltage does not rise above the low boundary before storage circuits are depleted. How long the loudspeaker will continue to function during brownout depends on the amount of voltage drop and the audio source level during the drop. If the voltage increases above the upper boundary of the range, the power supply can be damaged.

It is recommended that the voltage supply be within the rated voltage window. This ensures that AC voltage variations from the service entry - or peak voltage drops due to cable runs - do not cause the amplifier to cycle on and off or cause damage to the power supply.

For best performance, the AC cable voltage drop should not exceed 10 volts, or 10 percent at 115 volts and 5 percent at 230 volts.

Make sure that even with the AC voltage drop, the AC voltage always stays within recommended operating ranges. The minimum electrical service amperage required by an EX26 speaker system is the sum of each loudspeaker's maximum continuous rms current. An additional 50 percent above that amperage is recommended to prevent peak voltage drops at the service entry.

The Power Connector

The EX28 requires a grounded outlet. It is very important that the loudspeaker AC supply be properly grounded in order to operate safely and properly. Use the PowerCon AC cable wiring diagram overleaf to create international or special-purpose power connectors:

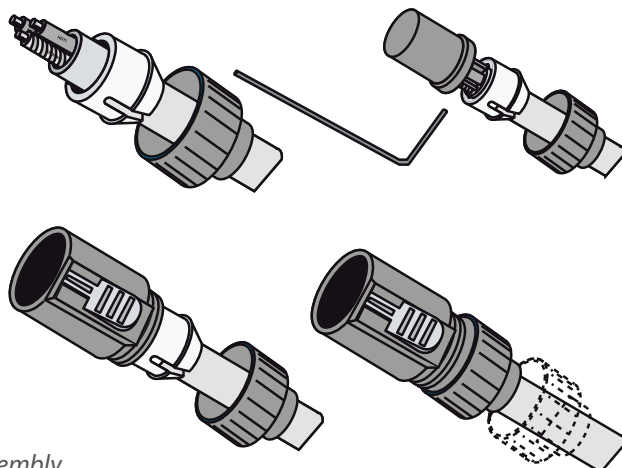

Power connector assembly

Current Requirements

Each EX28 requires approximately 4 Amps max at 115 V AC for proper operation. This allows up to three EX28's to be powered from one 15 A breaker at 115 V and up to seven EX28's at 230 V.

The EX28 presents a dynamic load to the AC mains, which causes the amount of current to fluctuate depending on quiet or loud operating levels. Since different cables and circuit breakers heat up at varying rates, it is essential to understand the types of current ratings and how they correspond to circuit breaker and cable specifications.

The maximum long-term continuous current is the maximum rms current during a period of at least ten seconds. It is used to calculate the temperature rise in cables, in order to select a cable size and gauge that conforms to electrical code standards. It is also used to select the rating for slow-reacting thermal breakers.

The burst current is the maximum rms current during a period of approximately one second, used to select the rating of most magnetic breakers and to calculate the peak voltage drop in long AC cables according to the formula:
 $V_{pk}(\text{drop}) = I_{pk} \times R(\text{cable total})$

The ultimate short-term peak current is used to select the rating of fast reacting magnetic breakers. Use the table below as a guide when selecting cable gauge size and circuit breaker ratings for your operating voltage.

Current Draw	115 V Mode	230 V Mode
Max Long Term Continuous	4 A rms	2 A rms
Burst Current	6 A rms	4 A rms
Short Term Peak	16 A peak	8 A peak

AC Cable Color Coding

If the colours referred to in the diagram don't correspond to the terminals in your plug, use the following guidelines: *Connect the blue wire to the terminal marked with a N or coloured black. Connect the brown wire to the terminal marked with a L or coloured red. Connect the green and yellow wire to the terminal marked with a E or coloured green or green and yellow.*

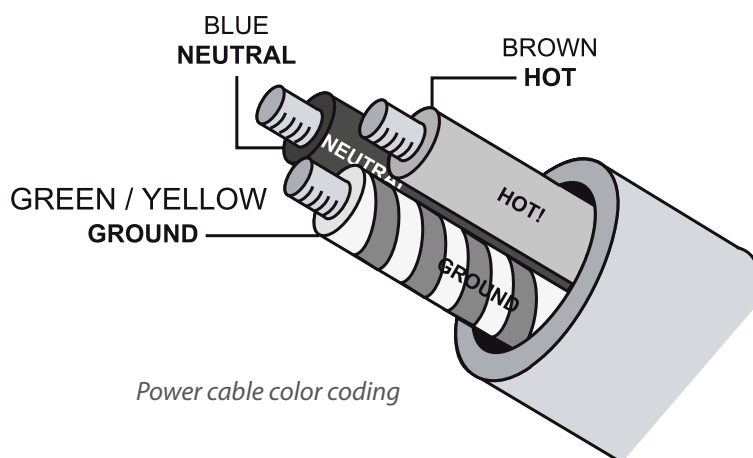

The EX28 requires a ground connection. Always use a grounded outlet and plug.

The EX28 Control Panel

The EX28 features an easy to use control panel featuring AC power in, audio input and through output, level control, LED status light and a High Pass filter.

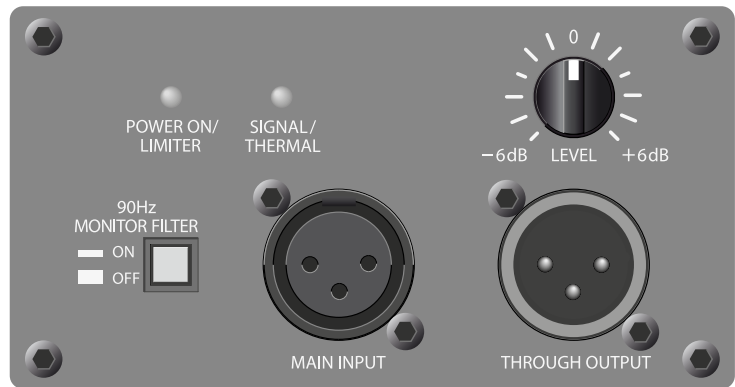

EX28 Rear panel

Audio Input and Output

The EX28 uses a balanced, female XLR connector for the audio input connector, and a male XLR connector to provide through output signal. The through output connector, wired in parallel to the audio input, will continue to provide the input signal if the EX28 is turned off. The audio input circuit presents a 20 kΩ balanced input impedance to a three-pin XLR connector with the following connections:



Main input



Through output

- Pin 1 - Ground
- Pin 2 - Signal (+)
- Pin 3 - Signal (-)
- Case - Earth (AC) ground and chassis

Audio signal can be daisy-chained using the through output connector on the input panel. A single source can drive multiple EX28 speakers with a paralleled input loop. If you are driving multiple EX28's make certain that the source device can drive the total load impedance presented by the paralleled input circuits.

The audio source must be capable of producing a minimum of 1.0V volts rms to produce the maximum peak SPL over the operating bandwidth of the loudspeaker. To avoid distortion from the source, make sure the source equipment provides an adequate drive circuit design for the total paralleled load impedance presented by the speakers. The input impedance for a single loudspeaker is 20 kΩ. If "n" represents the number of EX28 loudspeakers in a system, paralleling the inputs of n loudspeakers will produce a balanced input load of 20 kΩ divided by "n".

If the loudspeaker produces noises such as hiss and popping, disconnect the audio cable from the loudspeaker, if the noise stops, then most likely the problem is not with the loudspeaker. Check the audio cable, source, and AC power for the source of the problem.

Ensure that all cabling carrying signal to multiple amplifiers and active speaker systems is wired correctly. Make sure that the polarity has not been reversed. Reversed polarity can cause severe degradation in frequency response and can also impact the dispersion characteristics of the speaker.

Power On / Signal LED

This LED turns green when the speaker is turned ON. The light will turn yellow when signal is present.

Low Cut Switch

The EX28 features a 90 Hz High Pass Filter. Pressing the button engages this filter allowing the speaker to reproduce frequencies only above 90 Hz.

Limiter

The EX28 employs a protection system based on rms limiting of the amplifiers. This type of protection strategy allows the speaker to operate safely under overload conditions. When the rms "limiter" engages, the output level of both amplifiers is reduced to a safe operating level. This type of protection allows the frequency response of the system to remain unchanged as the level is lowered. By not compressing or limiting peak signal, dynamics also remain unchanged. The control objective is to regulate the operating temperature of the transducers magnetic circuits long term. This ensures no impact on performance due to power compression and allows the components to retain their ability to reproduce high dynamics. When overdriven the rms limiter will disengage only if the input level is turned down.

Thermal Protection

In the unlikely event of over heating the speaker system will shut down. You can expect for the system to be down for at least 2-3 minutes depending on the ambient temperature and whether the system is being exposed to direct sun light.

The EX28 features a fin-less heatsink that allows it to operate in any position. There is also an internal fan located inside the amplifier module. The fan speed is dependent on two factors; the temperature of the heat sink and the output level of the speaker. As temperature increases, so does fan speed. As audio level increases, fan speed also increases as a preventative measure designed to keep the heat sink temperature low. Under normal operating conditions, the fan noise remains inaudible. Please contact KV2 Audio or a local service representative should the system enter a thermal condition under normal operating conditions.

Specifications

System Acoustic Performance

Max SPL Long-term	126 dB
Max SPL Peak	132 dB
-3 dB Response	62 Hz to 20 kHz
-10 dB Response	52 Hz to 28 kHz
Crossover Point	2 kHz

High Frequency Section

Acoustic Design	Horn Loaded
High Horn Coverage Horizontal / Vertical	100° x 80°
Rotatable Horn	YES
Throat Exit Diameter / Diaphragm Size	1" / 1.75"
Diaphragm Material	Titanium
Magnet Type	Neodymium

High Frequency Amplifier Specification

Type	Class AB Push-Pull
Rated Continuous Power	50 W
Distortion	<0.05%
Operating Bandwidth	2.0 kHz to 28 kHz

Low Frequency Section

Acoustic Design	Front Loaded, Bass Reflex
Woofer Size / Voice Coil Diameter	8" / 2" (one feat. Trans coil)
Magnet Type	Neodymium
Diaphragm Material	Epoxy Reinforced Cellulose

Low Frequency Amplifier Specification

Type	High efficiency, Current-Enhancing, Switched-Rail Amplifier
Rated Continuous Power	450 W
Distortion	<0.05%
Operating Bandwidth	62 Hz to 2.0 kHz

Signal Input

Input Sensitivity	0,775 V RMS
Input Impedance	20 kΩ

Power

Power Connector	Neutrik PowerCon®
Operating Voltage Range	100 to 120 V @ 60 Hz 230 to 250 V @ 50 Hz
Recommended Amperage	6 A 115 V / 3 A 230 V

Cabinet

Cabinet Material	Baltic birch
Handles	1
Pole Mount	35 mm
Color	"Orange peeled" Matt Black or any RAL

Physical Dimensions

Height	668 mm (26.29")
Width	260 mm (10.23")
Depth	320 mm (12.59")
Weight	23 kg (50.7 lb)

Frequency response

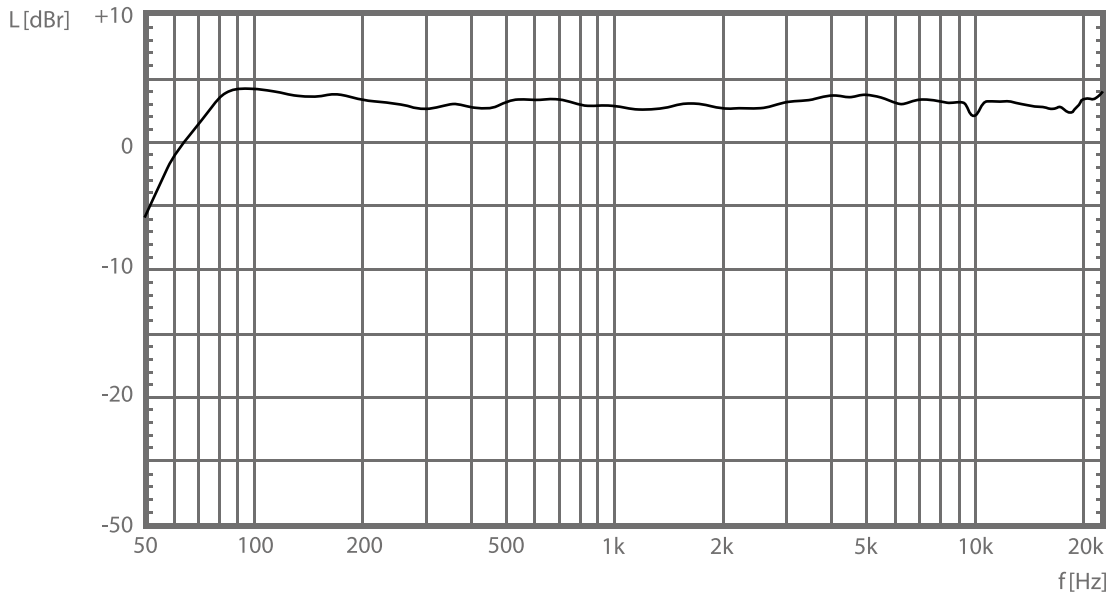

Horizontal Polarplots

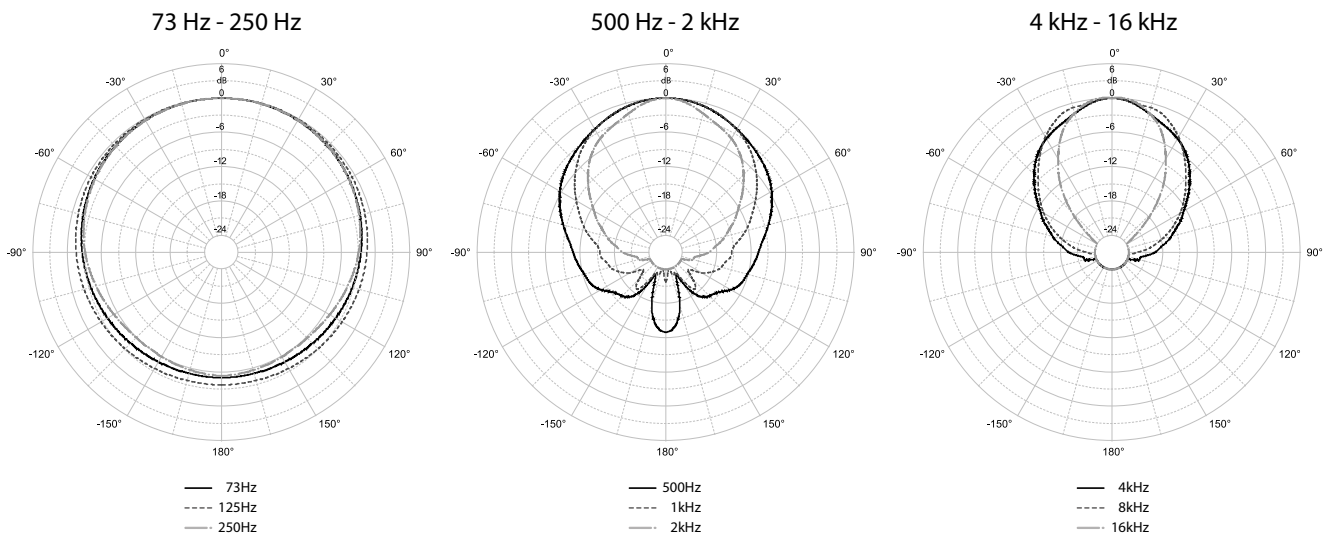

Vertical Polarplots

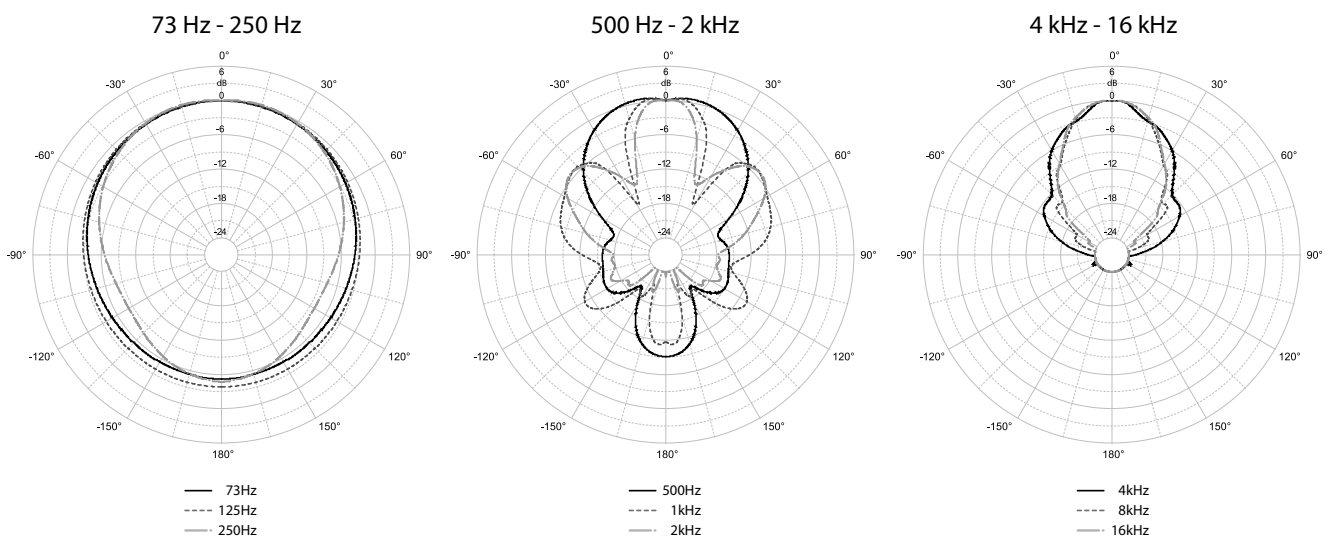

Drawings

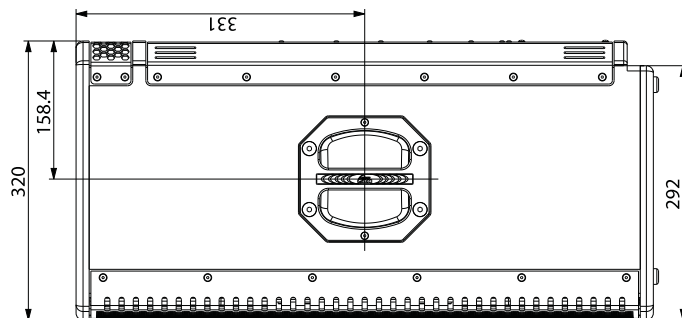
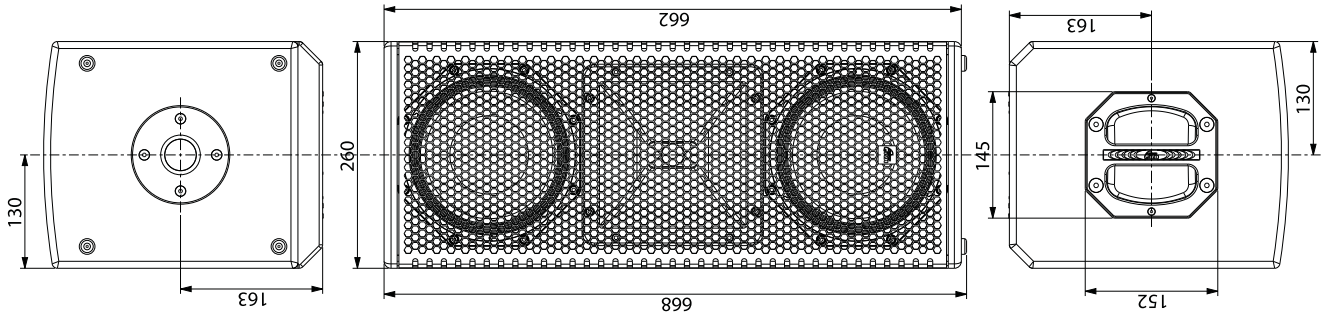
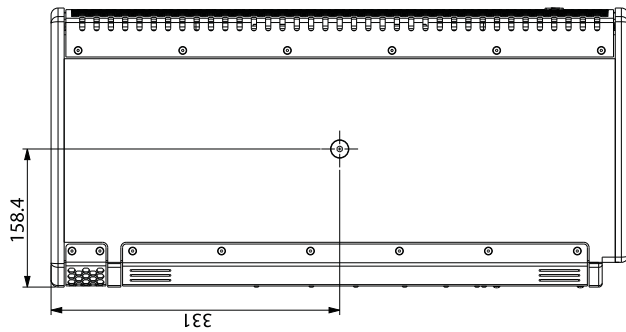
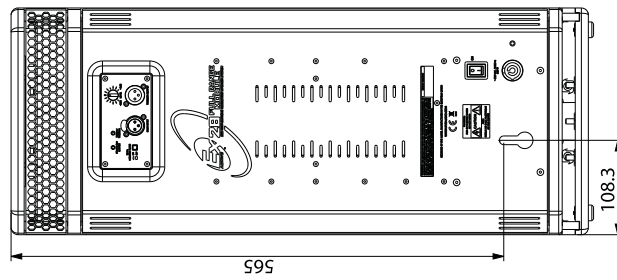
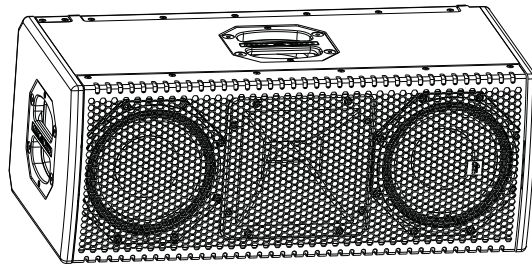

EX12 FULL RANGE MODULE

ACTIVE

500 WATT EXTREME RESOLUTION SPEAKER SYSTEM

EX10 - part number KVV 987 095 (250V)

KVV 987 059 (230V)

KVV 987 060 (115V)

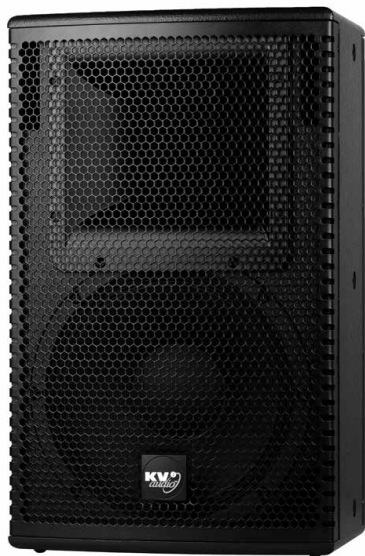

Application

Designed for the highest quality vocal and full range live performance in medium size applications

- Suitable for medium to large conference, Theatre and small to medium scale concerts
- Scalable from stand alone to full range large systems incorporating
- EX subwoofers
- Fixed installations
- Stage monitoring

Introduction

The EX12 is a 2-way high output, active, compact, fullrange speaker system. Design objectives for the EX12 were focused on the expansion of KV2 Audio's primary philosophy of speakers systems with increased dynamic range, very high output and a consistent sound character no matter what the output level. The EX12 sets new levels of performance for compact cabinets achieved through the integration of new amplifier, transducer and electronic control technologies that are closely tied to a passion for taking performance to the next level.

Electronics

Amplifier power, electronic crossovers, phase alignment, equalization, time correction and speaker protection are integrated into the EX12's amplifier module. On-board electronics ensures fast, easy set up and complete control. An improved version of KV2 Audio's switch mode, current enhancing low frequency amplifier has been developed for the EX12. The new configuration improves overall system efficiency and increases output, allowing passive radiation of heat to take place through a unique "fin-less" heat sink that can be placed in any position or direction. This ensures cool operation in horizontal or vertical applications. Additionally, the EX12 amplifier unit contains an internally located electric fan that is operated by a temperature sensing circuit which will slowly bring the fan online as required in extreme, high temperature situations.

Months of research were invested into designing circuitry that ensures that the extreme dynamic range exemplified by the speaker system is maintained even under clipping conditions. The real test of the EX12 's limits is when it is exposed to the rigors and demands of live audio playback where consistent clipping of amplifiers, generation of distortion artifacts, dramatic increases in the floor and the elimination of dynamic range put the product to an extreme test.

The EX12's high frequency compression driver is powered and controlled by KV2 Audio's standard low intermodulation distortion, Class A/B, push-pull circuitry, high and mid frequency amplifier design. Metal Oxide Silicon Field Effect Transistors (MOSFET) are used for the output stage and the compression driver coupled through a transformer balanced speaker output. The entire performance strategy for this type of design is based on producing the lowest intermodulation distortion possible and the highest audio quality in the critical mid and high operating bands.

Acoustic Components

KV2 Audio has developed a revolutionary woofer technology called Trans-Coil™. The woofer has two coils, a standard voice coil assembly and a second coil placed directly on the neodymium magnetic circuit's pole piece. This technology eliminates voice coil inductance resulting in a flat impedance response above the resonance point and achieves faster transient response through increased force and control of the moving mass. It also linearises acoustic and electrical phase response, reduces harmonic distortion and increases power transfer and transducer speed. Through this technology, the speaker now behaves like both a woofer at lower frequencies and like a mid-range at higher frequencies allowing a seamless transition to take place at the crossover frequency.

The EX12's neodymium compression driver is loaded on a constant directivity horn designed for smooth, wide dispersion performance. More importantly, it has also been designed to precisely match the power response of the woofer at the crossover frequency, a crucial design objective that ensures smooth transition and minimizes anomalies.

The compression driver is a new, 3.00-inch titanium diaphragm design, featuring a radial phase plug, progressive parabolic semi-circle suspension, direct-drive nomex voice coil assembly and the industry's largest neodymium magnetic motor structure. Each feature was developed over an extended period of time and implemented as part of a strategy to lower distortion, increase output and improve response characteristics.

The EX12 horn was designed with one primary performance goal. The horn design is based on constant-directivity geometry with an emphasis on generating very low air distortion artifacts, maintaining low transducer compression ratios, high output and wide dispersion (80 x 40). The horn is an injected moulded aluminium part that functions as a heat dissipater for the compression driver's neodymium magnetic motor structure.

Enclosure Design

The EX12 is a very compact, asymmetrical geometry enclosure design allowing it to be used in a variety of applications and featuring a number of ergonomically designed components that make it lightweight and easy to use. An extensive set of professional hardware features enables the EX12 to be used in a variety of environments using an array of industry standard hardware. These facilitate both portable and fixed installations with a maximum amount of mounting flexibility.

A specially molded aluminum top handle was designed and fitted to the top of the cabinet. It functions as the principle pick up handle as well as providing several fixed installation and hanging solutions. It has a centrally located M10 hang point as well as four additional M6 bracket points. The handles four principal mounting bolts also provide an Omnimount™ bracket point. There are two side-mounted M10 hang points that can be used with brackets or eyebolts.

AC Power

The EX12 uses a PowerCon 3-pole AC main system with locking connectors to prevent accidental disconnection. The main AC connector (blue) serves as the power input.

The EX12 operates in either 115 V, 230 V or 250 V modes. Although pre-configured at the factory, the unit's operating voltage mode can be changed in the field.

Voltage Requirements

The EX12 operates safely and without audio discontinuity if the AC voltage stays within the operating window of 100 V-120 V in 115 V mode, 205 V-240 V in 230 V mode and 225 V-260 V when working in 250 V mode, at 50 or 60 Hz.

If the On LED does not illuminate or the system does not respond to audio input, remove AC power immediately. Verify that the voltage is within the proper range. If the problem persists, please contact KV2 Audio or an authorized service center.

If the voltage drops below the low boundary of its safe operating range, the loudspeaker will shut down if the voltage does not rise above the low boundary before storage circuits are depleted. How long the loudspeaker will continue to function during brownout depends on the amount of voltage drop and the audio source level during the drop.

If the voltage increases above the upper boundary of the range, the power supply can be damaged.

It is recommended that the voltage supply be within the rated voltage window. This ensures that AC voltage variations from the service entry- or peak voltage drops due to cable runs - do not cause the amplifier to cycle on and off or cause damage to the power supply.

For best performance, the AC cable voltage drop should not exceed 10 volts, or 10 percent at 115 volts and 5 percent at 230 volts.

Make sure that even with the AC voltage drop, the AC voltage always stays within recommended operating ranges. The minimum electrical service amperage required by a EX12 speaker system is the sum of each loudspeaker's maximum continuous rms current. An additional 50 percent above the minimum amperage is recommended to prevent peak voltage drops at the service entry.

The Power Connector

The EX12 requires a grounded outlet. It is very important that the loudspeaker AC supply be properly grounded in order to operate safely and properly. Use the PowerCon AC cable-wiring diagram on page 36 to create international or special-purpose power connectors:

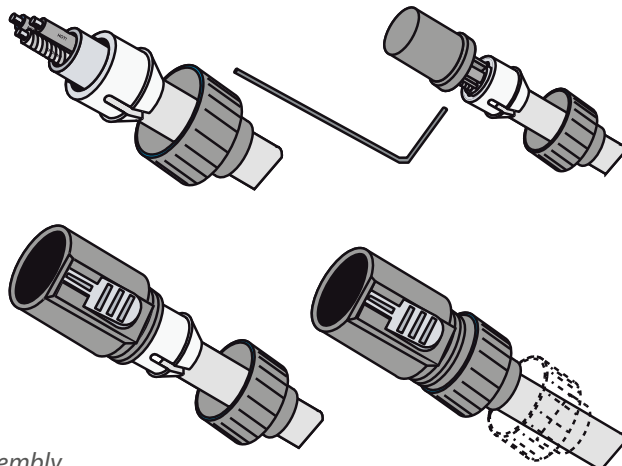

Power connector assembly

Current Requirements

Each EX12 requires approximately 5 Amps max at 115 V AC for proper operation. This allows up to three EX12's to be powered from one 15 A breaker at 115 V and up to 6 loudspeakers at 230 V or 250 V.

The EX12 presents a dynamic load to the AC mains, which causes the amount of current to fluctuate depending on quiet or loud operating levels. Since different cables and circuit breakers heat up at varying rates, it is essential to understand the types of current ratings and how they correspond to circuit breaker and cable specifications.

The maximum long-term continuous current is the maximum rms current during a period of at least ten seconds. It is used to calculate the temperature rise in cables, in order to select a cable size and gauge that conforms to electrical code standards. It is also used to select the rating for slow-reacting thermal breakers.

The burst current is the maximum rms current during a period of approximately one second, used to select the rating of most magnetic breakers and to calculate the peak voltage drop in long AC cables according to the formula:
 $V_{pk}(\text{drop}) = I_{pk} \times R(\text{cable total})$

The ultimate short-term peak current is used to select the rating of fast reacting magnetic breakers. Use the table below as a guide when selecting cable gauge size and circuit breaker ratings for your operating voltage.

Current Draw	115 V Mode	230 V, 250 V
Max Long Term Continuous	5 A rms	2.5 A rms
Burst Current	7.5 A rms	5 A rms
Short Term Peak	20 A peak	10 A peak

AC Cable Color Coding

If the colors referred to in the diagram don't correspond to the terminals in your plug, use the following guidelines:
 Connect the blue wire to the terminal marked with a N or colored black. Connect the brown wire to the terminal marked with a L or colored red. Connect the green and yellow wire to the terminal marked with a E or colored green or green and yellow.

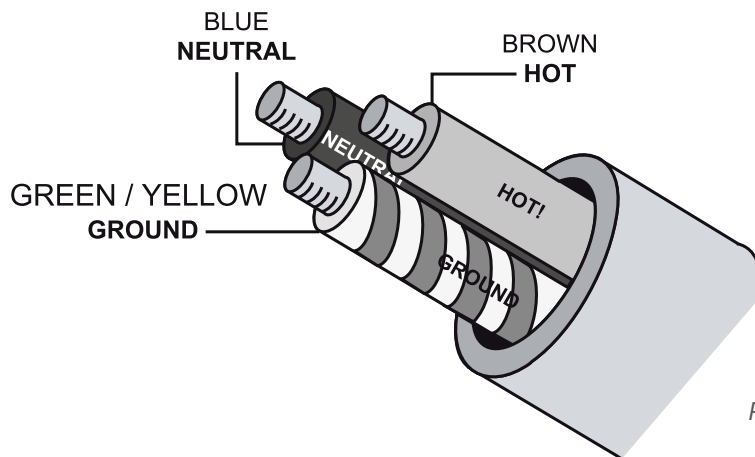

Power cable color coding

The EX12 requires a ground connection. Always use a grounded outlet and plug.

The EX12 Control Panel

The EX12 features an easy to use rear control panel featuring audio input and output, level control, LED status lights and a low pass filter that can be engaged when the loudspeaker is used as a stage monitoring device.

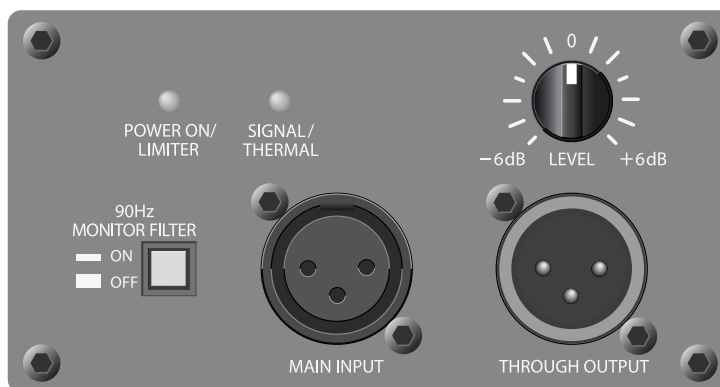

EX12 Rear panel

Audio Input and Output

The EX12 uses a balanced, female XLR connector for the audio input connector, and a male XLR connector to provide through output signal. The through output connector, wired in parallel to the audio input, will continue to provide the input signal if the EX12 is turned off. The audio input circuit presents a 20 kOhm balanced input impedance to a three-pin XLR connector with the following connectors:



Main input



Through output

- Pin 1 - Ground
- Pin 2 - Signal (+)
- Pin 3 - Signal (-)
- Case - Earth (AC) ground and chassis

Audio signal can be daisy-chained using the through output connector on the input panel. A single source can drive multiple EX12 speakers with a paralleled input loop. If you are driving multiple EX12's in an array, make certain that the source device can drive the total load impedance presented by the paralleled input circuit of the array.

The audio source must be capable of producing a minimum of 20 dB volts (10 volts rms into 600 ohms) to produce the maximum peak SPL over the operating bandwidth of the loudspeaker. To avoid distortion from the source, make sure the source equipment provides an adequate drive circuit design for the total paralleled load impedance presented by the array. The input impedance for a single loudspeaker is 20 kOhms. If "n" represents the number of EX12 loudspeakers in a system, paralleling the inputs of n loudspeakers will produce a balanced input load of 20 kOhms divided by "n".

Most source equipment is safe for driving loads no smaller than 10 times the source's output impedance. For example, cascading an array of 10 units consisting of EX12 speakers produces an input impedance of 2000 ohms (20kOhms divided by 10). The source equipment should have output impedance of 200 ohms or less. This is also true when connecting EX12's in parallel (loop out) with other KV2 Audio amplifiers and active speakers and subwoofers.

If the loudspeaker produces noises such as hiss and popping, disconnect the audio cable from the loudspeaker, if the noise stops, then most likely the problem is not with the loudspeaker. Check the audio cable, source, and AC power for the source of the problem.

Ensure that all cabling carrying signal to multiple amplifiers and active speaker systems is wired correctly. Make sure that the polarity has not been reversed. Reversed polarity can cause severe degradation in frequency response and can also impact the dispersion characteristics of the speaker.

Amplifiers and Acoustic Filters

The EX12 is powered by two separate power amplifiers specifically designed and optimised for the low frequency and high frequency drivers. The control system in the EX12 processes the audio signal through a series of electronic filters and circuits providing equalization, crossover filters, phase adjustment, thermal and overdrive protection.

The EX12 employs a protection system based on rms limiting of the amplifiers. This type of protection strategy allows the speaker to operate safely under overload conditions. When the rms "limiter" engages, the output level of both amplifiers is reduced to a safe operating level. This type of protection allows the phase response of the system to remain unchanged as the level is lowered. Buy not compressing or limiting peak signal, dynamics also remain unchanged. The control objective is to regulate the operating temperature of the transducers magnetic circuits long term. This ensures no impact on performance due to power compression and allows the components to retain their ability to reproduce high dynamics.

LED Status Lights

The EX12 control panel uses two distinct LED's to provide operating status information.

Power On / Limiter LED

This LED turns green when the speaker is turned ON. The light will continue to be green during normal operation of the speaker system. Should the rms limiting system be engaged due to overdriving of the EX12, the LED will change color from green to yellow. The audible effect of the rms limiter is a lowering of overall output level. The rms limiter will disengage only if the input level is turned down.

Signal / Thermal LED

This LED turns green when there is audio signal present in the EX12. This signal indicator can be used to troubleshoot wiring problems. The LED will change from green to yellow under a thermal condition resulting from overheating of the amplifier system. Under this condition, the speaker system will shut down. You can expect for the system to be down for at least 2-3 minutes depending the ambient temperature and whether the system is being exposed to direct sun light.

The EX12 features a finless heatsink that allows it to operate in any position. There is also an internal fan located inside the amplifier module. The fan speed is dependent on two factors; the temperature of the heat sink and the output level of the speaker. As temperature increases, so does fan speed. As audio level increases, fan speed also increases as a preventative measure designed to keep the heat sink temperature low. Under normal operating conditions, the fan noise remains inaudible. Please contact KV2 Audio or a local service representative should the system enter a thermal condition under normal operating conditions.

Stage Monitor Filter

The EX12 features a 90 Hz Monitor Filter control. Depressing the button engages a low pass audio filter allowing the speaker to be effectively used to reproduce frequencies above 90 Hz.

When using EX12 as a stage monitor, the horn should be rotated 90°.

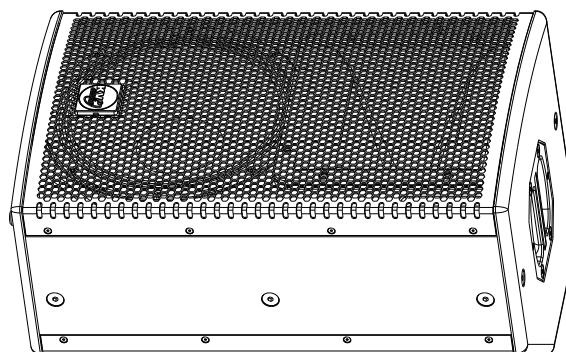

Specifications

System Acoustic Performance

Max SPL Long-term	127 dB
Max SPL Peak	133 dB
-3 dB Response	55 Hz to 22 kHz
-10 dB Response	45 Hz to 30 kHz
Crossover Point	1.1 kHz

High Frequency Section

Acoustic Design	Horn Loaded
High Horn Coverage Horizontal / Vertical	80° x 40°
Rotatable Horn	NO
Throat Exit Diameter / Diaphragm Size	1.4" / 3"
Diaphragm Material	Nitride Titanium
Magnet Type	Neodymium

High Frequency Amplifier Specification

Type	Class AB Push-Pull
Rated Continuous Power	50 W
Distortion	<0.05%
Operating Bandwidth	1.1 kHz to 30 kHz

Low Frequency Section

Acoustic Design	Front Loaded, Bass Reflex
Woofer Size / Voice Coil Diameter / Design	12" / 3.0" / Trans Coil
Magnet Type	Neodymium
Diaphragm Material	Epoxy Reinforced Cellulose

Low Frequency Amplifier Specification

Type	High efficiency, Current-Enhancing, Switched-Rail Amplifier
Rated Continuous Power	450 W
Distortion	<0.05%
Operating Bandwidth	45 Hz to 1.1 kHz

Signal Input

Input Sensitivity	1.0 V RMS
Input Impedance	20 kΩ

Power

Power Connector	Neutrik PowerCon®
Operating Voltage Range	100 to 120 V @ 60 Hz 205 to 240 V @ 50 Hz 225 to 260 V @ 50 Hz
Recommended Amperage	6 A 115 V 3 A 230 V 3 A 250 V

Cabinet

Cabinet Material	Baltic birch
Handles	2
Pole Mount	35 mm
Color	"Orange peeled" Matt Black or any RAL

Physical Dimensions

Height	596 mm (23.46")
Width	368 mm (14.49")
Depth	368 mm (14.49")
Weight	27.4 kg (60.4 lb)

Frequency response

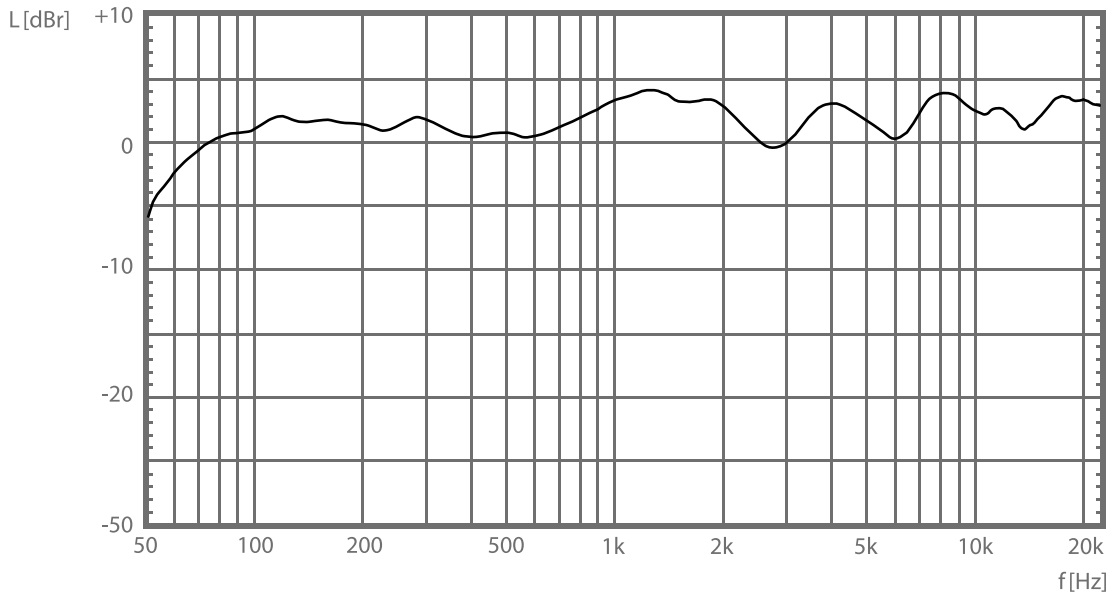

Horizontal Polarplots

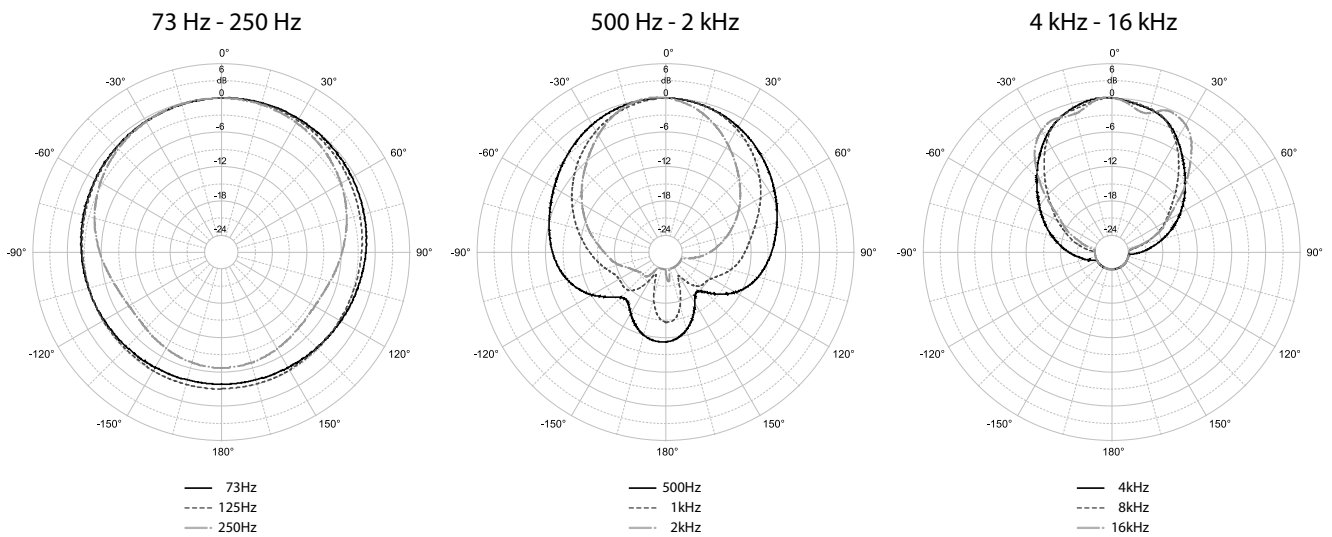

Vertical Polarplots

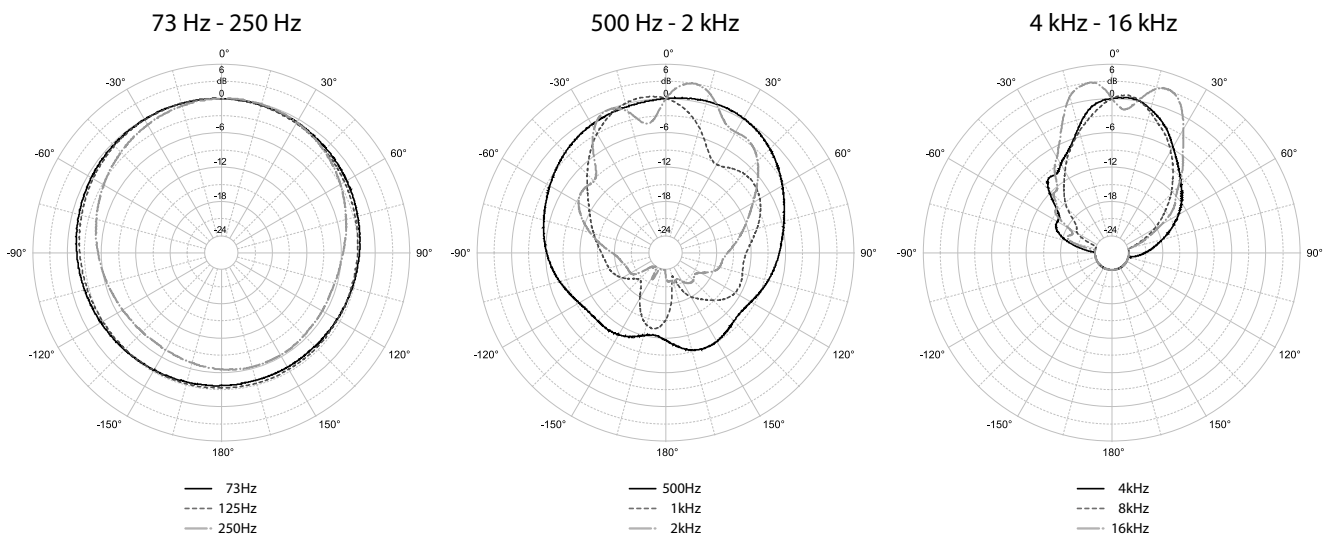

Drawings

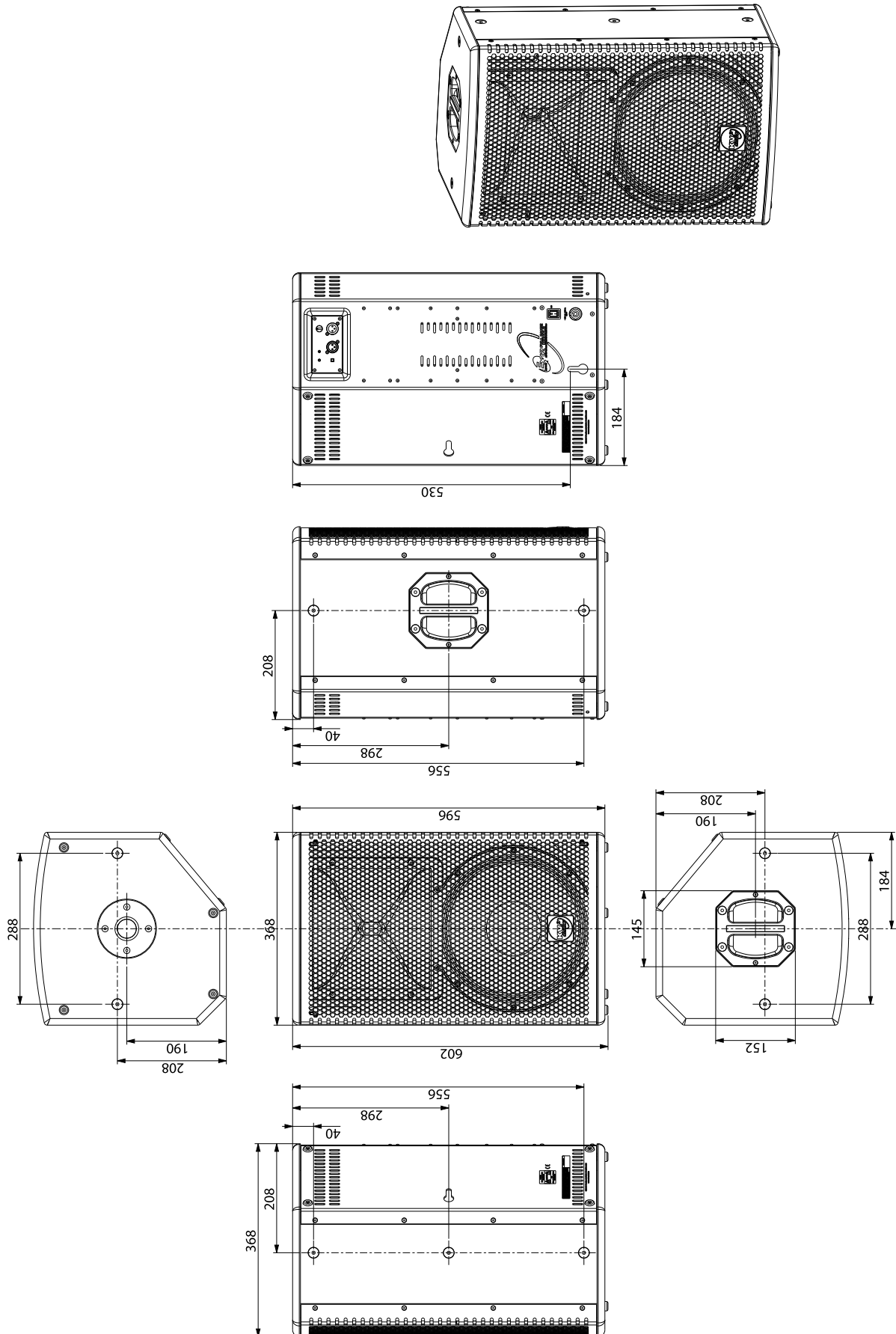

EX15 FULL RANGE MODULE

ACTIVE

1000 WATT EXTREME RESOLUTION SPEAKER SYSTEM

EX15 - part number KVV 987 267 (230V)
KVV 987 266 (115V)



Application

Primarily designed as a true full-range stand-alone device for multiple applications, whilst presenting the highest quality, definition and dynamic range

- Suitable for medium to large conference
- Theatre and small to medium scale concerts
- Scalable, can be used if required with EX subwoofers
- Portable or fixed installations

Introduction

The EX15 is a 3-way high output, active, fullrange speaker system. Design objectives for the EX15 were to present our consistent focused expansion of KV2 Audio's primary philosophy of speakers systems, with increased dynamic range, very high output and a recognisable sound character no matter what the output level. The EX15 sets new levels of performance for compact full-range cabinets, achieved through the integration of new amplifier, transducer and electronic control technologies that are closely tied to a passion for taking performance to the next level.

Electronics

Amplifier power, electronic crossovers, phase alignment, equalization, time correction and speaker protection are integrated into the EX15's amplifier module. On-board electronics ensure fast, easy set up and complete control. An improved version of KV2 Audio's switch mode, current enhancing low frequency amplifier has been developed for the EX15. The new configuration improves overall system efficiency and increases output allowing passive radiation of heat to take place through a unique "fin-less" heat sink that can be placed in any position or direction. This ensures cool operation in horizontal or vertical applications. Additionally, the EX15 amplifier unit contains an internally located electric fan that is operated by a temperature sensing circuit which will slowly bring the fan online as required in extreme, high temperature situations.

Months of research were invested into designing circuitry that ensures that the extreme dynamic range exemplified by the speaker system is maintained even under clipping conditions. The real test of the EX15's limits is when it is exposed to the rigors and demands of live audio playback where consistent clipping of amplifiers, generation of distortion artifacts, dramatic increases in the floor and the elimination of dynamic range put the product to an extreme test.

The EX15's high frequency compression driver is powered and controlled by KV2 Audio's standard low intermodulation distortion, Class A/B, push-pull circuitry, high and mid frequency amplifier design. Metal Oxide Silicon Field Effect Transistors (MOSFET) are used for the output stage and the compression driver coupled through a transformer balanced speaker output. The entire performance strategy for this type of design is based on producing the lowest intermodulation distortion possible and the highest audio quality in the critical mid and high operating bands.

Acoustic Components

The new EX15 incorporates a unique coaxial 15" transducer with a 1.75" Nitride Titanium Neodymium Compression Driver on a wide dispersion 80 x 60 degree horn. Whilst most coaxial speakers will try to cover the full frequency response, the EX15's coaxial driver only covers bass and highs leaving the all important mid-range to a 6" neodymium speaker mounted on a large 80 x 60 degree horn. This resolves the issue of the 15" driver trying and failing to reproduce mid-range, a common problem with conventional coaxial designs. The EX15's unique design provides extremely flat, full range reproduction from a compact yet powerful package that out performs speakers twice its size, weight and price.

Enclosure Design

The EX15 is a logistical compact, asymmetrical geometry enclosure design, allowing it to be used in a variety of applications and featuring a number of ergonomically designed components that make it easy to move and use. An extensive set of professional hardware features enables the EX15 to be used in a variety of environments using an array of industry standard hardware. These facilitate both portable and fixed installations with a maximum amount of mounting flexibility.

AC Power

The EX15 uses a PowerCon 3-pole AC main system with locking connectors to prevent accidental disconnection. The main AC connector (blue) serves as the power input.

The EX15 operates in either 115 V, 230 V or 250 V modes. Although pre-configured at the factory, the unit's operating voltage mode can be changed in the field.

Voltage Requirements

The EX15 operates safely and without audio discontinuity if the AC voltage stays within the operating window of 100 V-120 V in 115 V mode, 205 V-240 V in 230 V mode and 225 V-260 V when working in 250 V mode, at 50 or 60 Hz.

If the On LED does not illuminate or the system does not respond to audio input, remove AC power immediately. Verify that the voltage is within the proper range. If the problem persists, please contact KV2 Audio or an authorized service center.

If the voltage drops below the low boundary of its safe operating range, the loudspeaker will shut down if the voltage does not rise above the low boundary before storage circuits are depleted. How long the loudspeaker will continue to function during brownout depends on the amount of voltage drop and the audio source level during the drop. If the voltage increases above the upper boundary of the range, the power supply can be damaged.

It is recommended that the voltage supply be within the rated voltage window. This ensures that AC voltage variations from the service entry- or peak voltage drops due to cable runs do not cause the amplifier to cycle on and off or cause damage to the power supply.

For best performance, the AC cable voltage drop should not exceed 10 volts, or 10 percent at 115 volts and 5 percent at 230 volts.

Make sure that even with the AC voltage drop, the AC voltage always stays within recommended operating ranges. The minimum electrical service amperage required by a EX15 speaker system is the sum of each loudspeaker's maximum continuous rms current. An additional 50 percent above the minimum amperage is recommended to prevent peak voltage drops at the service entry.

The Power Connector

The EX15 requires a grounded outlet. It is very important that the loudspeaker AC supply be properly grounded in order to operate safely and properly. Use the PowerCon AC cable-wiring diagram to create international or special-purpose power connectors:

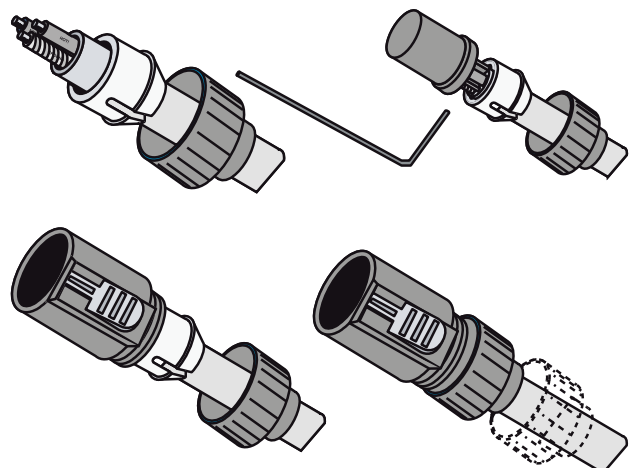

Power connector assembly

Current Requirements

Each EX15 requires approximately 5 Amps max at 115 V AC for proper operation. This allows up to three EX15's to be powered from one 15 A breaker at 115 V and up to 6 loudspeakers at 230 V or 250 V.

The EX10 presents a dynamic load to the AC mains, which causes the amount of current to fluctuate depending on quiet or loud operating levels. Since different cables and circuit breakers heat up at varying rates, it is essential to understand the types of current ratings and how they correspond to circuit breaker and cable specifications.

The maximum long-term continuous current is the maximum rms current during a period of at least ten seconds. It is used to calculate the temperature rise in cables, in order to select a cable size and gauge that conforms to electrical code standards. It is also used to select the rating for slow-reacting thermal breakers.

The burst current is the maximum rms current during a period of approximately one second, used to select the rating of most magnetic breakers and to calculate the peak voltage drop in long AC cables according to the formula:
 $V_{pk}(\text{drop}) = I_{pk} \times R(\text{cable total})$

The ultimate short-term peak current is used to select the rating of fast reacting magnetic breakers. Use the table below as a guide when selecting cable gauge size and circuit breaker ratings for your operating voltage.

Current Draw	115 V Mode	230 V, 250 V
Max Long Term Continuous	5 A rms	2.5 A rms
Burst Current	7.5 A rms	5 A rms
Short Term Peak	20 A peak	10 A peak

AC Cable Color Coding

If the colors referred to in the diagram don't correspond to the terminals in your plug, use the following guidelines: *Connect the blue wire to the terminal marked with a N or colored black. Connect the brown wire to the terminal marked with a L or colored red. Connect the green and yellow wire to the terminal marked with a E or colored green or green and yellow.*

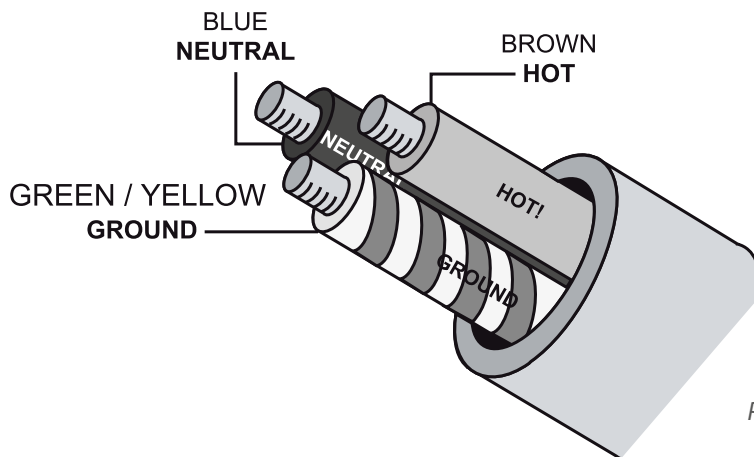

Power cable color coding

The EX15 requires a ground connection. Always use a grounded outlet and plug.

The EX15 Control Panel

The EX15 features an easy to use rear control panel with audio input and output, level control, high and low frequency gain controls and LED status lights.



EX15 Rear panel

Audio Input and Output

The EX15 uses a balanced, female XLR connector for the audio input connector, and a male XLR connector to provide through output signal. The through output connector, wired in parallel to the audio input, will continue to provide the input signal if the EX15 is turned off. The audio input circuit presents a 20 kOhm balanced input impedance to a three-pin XLR connector with the following connectors:



Main input

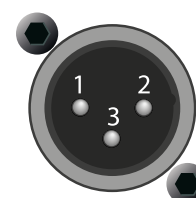

Through output

- Pin 1 - Ground
- Pin 2 - Signal (+)
- Pin 3 - Signal (-)
- Case - Earth (AC) ground and chassis

Audio signal can be daisy-chained using the through output connector on the input panel. A single source can drive multiple EX15 speakers with a paralleled input loop. If you are driving multiple EX15's in an array, make certain that the source device can drive the total load impedance presented by the paralleled input circuit of the array. The audio source must be capable of producing a minimum of 20 dB volts (10 volts rms into 600 ohms) to produce the maximum peak SPL over the operating bandwidth of the loudspeaker. To avoid distortion from the source, make sure the source equipment provides an adequate drive circuit design for the total paralleled load impedance presented by the array. The input impedance for a single loudspeaker is 20 kOhms. If "n" represents the number of EX15 loudspeakers in a system, paralleling the inputs of n loudspeakers will produce a balanced input load of 20 kOhms divided by "n".

Most source equipment is safe for driving loads no smaller than 10 times the source's output impedance. For example, cascading an array of 10 units consisting of EX15 speakers produces an input impedance of 2000 ohms (20kOhms divided by 10). The source equipment should have an output impedance of 200 Ohms or less. This is also true when connecting EX15's in parallel (loop out) with other KV2 Audio amplifiers and active speakers and subwoofers.

If the loudspeaker produces noises such as hiss and popping, disconnect the audio cable from the loudspeaker, if the noise stops, then most likely the problem is not with the loudspeaker. Check the audio cable, source, and AC power for the source of the problem.

Ensure that all cabling carrying signal to multiple amplifiers and active speaker systems is wired correctly. Make sure that the polarity has not been reversed. Reversed polarity can cause severe degradation in frequency response and can also impact the dispersion characteristics of the speaker.

Amplifiers and Acoustic Filters

The EX15 is powered by two separate power amplifiers specifically designed and optimized for the low frequency and high frequency drivers. The control system in the EX15 processes the audio signal through a series of electronic filters and circuits providing equalization, crossover filters, phase adjustment, thermal and overdrive protection.

The EX15 employs a protection system based on rms limiting of the amplifiers. This type of protection strategy allows the speaker to operate safely under overload conditions. When the rms "limiter" engages, the output level of both amplifiers is reduced to a safe operating level. This type of protection allows the phase response of the system to remain unchanged as the level is lowered. By not compressing or limiting peak signal, dynamics also remain unchanged. The control objective is to regulate the operating temperature of the transducers magnetic circuits long term. This ensures no impact on performance due to power compression and allows the components to retain their ability to reproduce high dynamics.

LED Status Lights

The EX10 control panel uses two distinct LED's to provide operating status information.

Power On / Limiter LED

This LED turns green when the speaker is turned ON. The light will continue to be green during normal operation of the speaker system. Should the rms limiting system be engaged due to overdriving of the EX15, the LED will change color from green to yellow. The audible effect of the rms limiter is a lowering of overall output level. The rms limiter will disengage only if the input level is turned down..

Signal / Thermal LED

This LED turns green when there is audio signal present in the EX15. This signal indicator can be used to troubleshoot wiring problems. The LED will change from green to yellow under a thermal condition resulting from overheating of the amplifier system. Under this condition, the speaker system will shut down. You can expect for the system to be down for at least 2-3 minutes depending the ambient temperature and whether the system is being exposed to direct sun light.

The EX15 features a finless heatsink that allows it to operate in any position. There is also an internal fan located inside the amplifier module. The fan speed is dependent on two factors; the temperature of the heat sink and the output level of the speaker. As temperature increases, so does fan speed. As audio level increases, fan speed also increases as a preventative measure designed to keep the heat sink temperature low. Under normal operating conditions, the fan noise remains inaudible. Please contact KV2 Audio or a local service representative should the system enter a thermal condition under normal operating conditions.

Specifications

System Acoustic Performance

Max SPL Long-term	129 dB
Max SPL Peak	135 dB
-3 dB Response	44 Hz to 18 kHz
-10 dB Response	38 Hz to 22 kHz
Crossover Point	500 Hz, 2.7 kHz

High Frequency Section

Acoustic Design	Horn Loaded
High Horn Coverage Horizontal / Vertical	80° x 60°
Throat Exit Diameter / Diaphragm Size	1" / 1.75"
Diaphragm Material	Nitride Titanium
Magnet Type	Neodymium
Protection	RMS Limiter

High Frequency Amplifier Specification

Type	Class AB Push-Pull
Rated Continuous Power	50 W
Distortion	<0.05%
Operating Bandwidth	2.7 kHz to 22 kHz

Mid Range Section

Acoustic Design	Horn Loaded
High Horn Coverage Horizontal / Vertical	80° x 60°
Woofer Size / Voice Coil Diameter / Design	6" / 1.5"
Diaphragm Material	Epoxy Reinforced Cellulose
Magnet Type	Neodymium
Protection	RMS Limiter

Low Frequency Section

Acoustic Design	Front Loaded, Bass Reflex
Woofer Size / Voice Coil Diameter	15" / 4"
Diaphragm Material	Epoxy Reinforced Cellulose
Magnet Type	Neodymium
Protection	RMS Limiter

Low Frequency Amplifier Specification

Type	High efficiency, Current-Enhancing, Switched-Rail Amplifier
Rated Continuous Power	850 W
Distortion	<0.05%
Operating Bandwidth	38 Hz to 500 kHz

Signal Input

Input Sensitivity	1.0 V RMS
Input Impedance	20 kΩ

Cabinet

Cabinet Material	Baltic birch
Handles	3
Pole Mount	35 mm
Color	"Orange peeled" Matt Black or any RAL

Physical Dimensions

Height	700 mm (27.55")
Width	450 mm (17.71")
Depth	450 mm (17.71")
Weight	43 kg (94.8 lb)

Frequency response

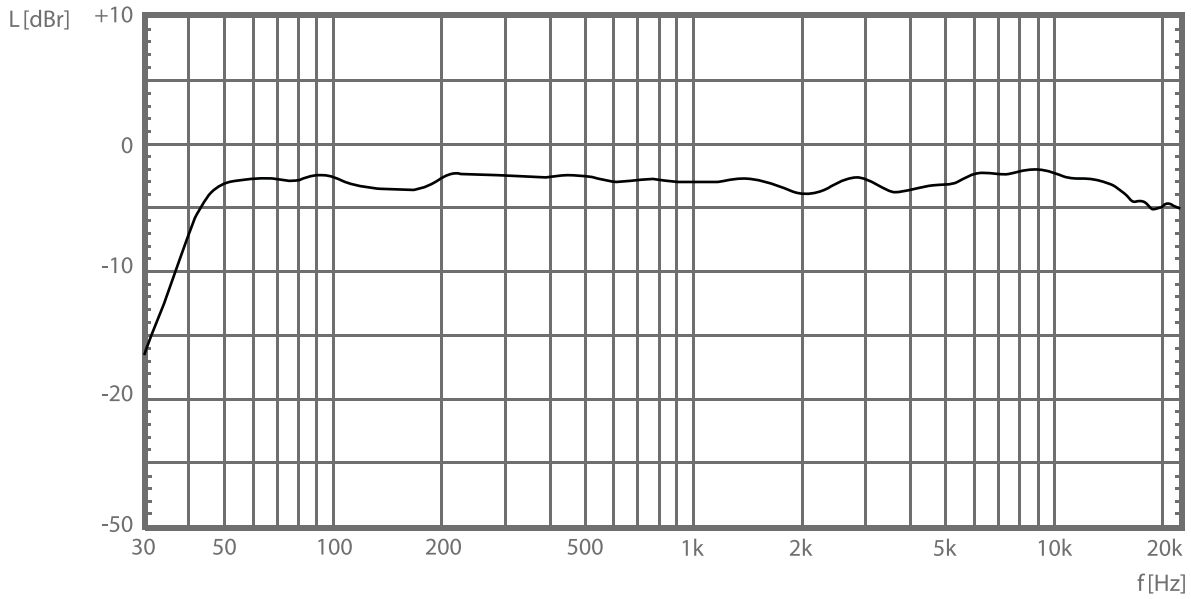

Horizontal Polarplots

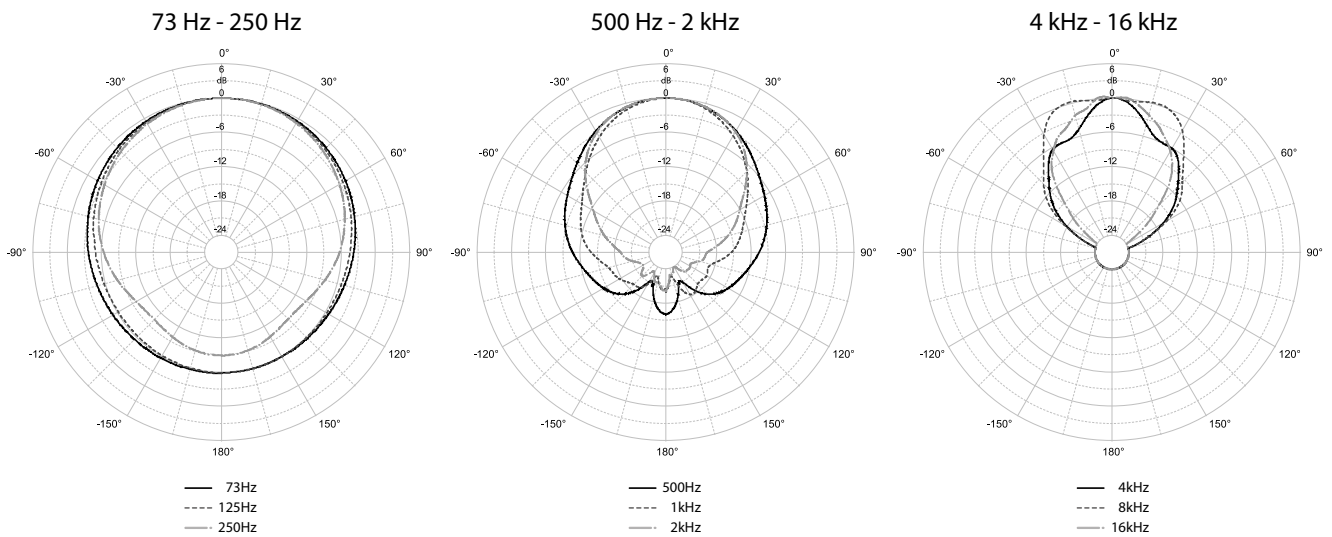

Vertical Polarplots

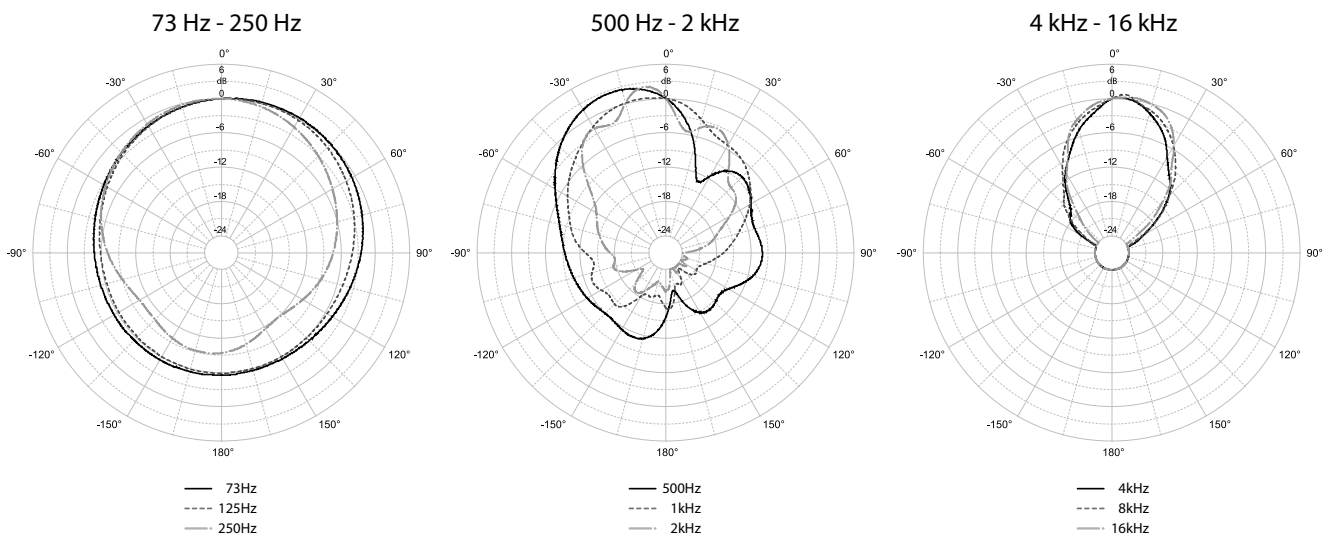

EX15 · Frequency characteristics

Drawings

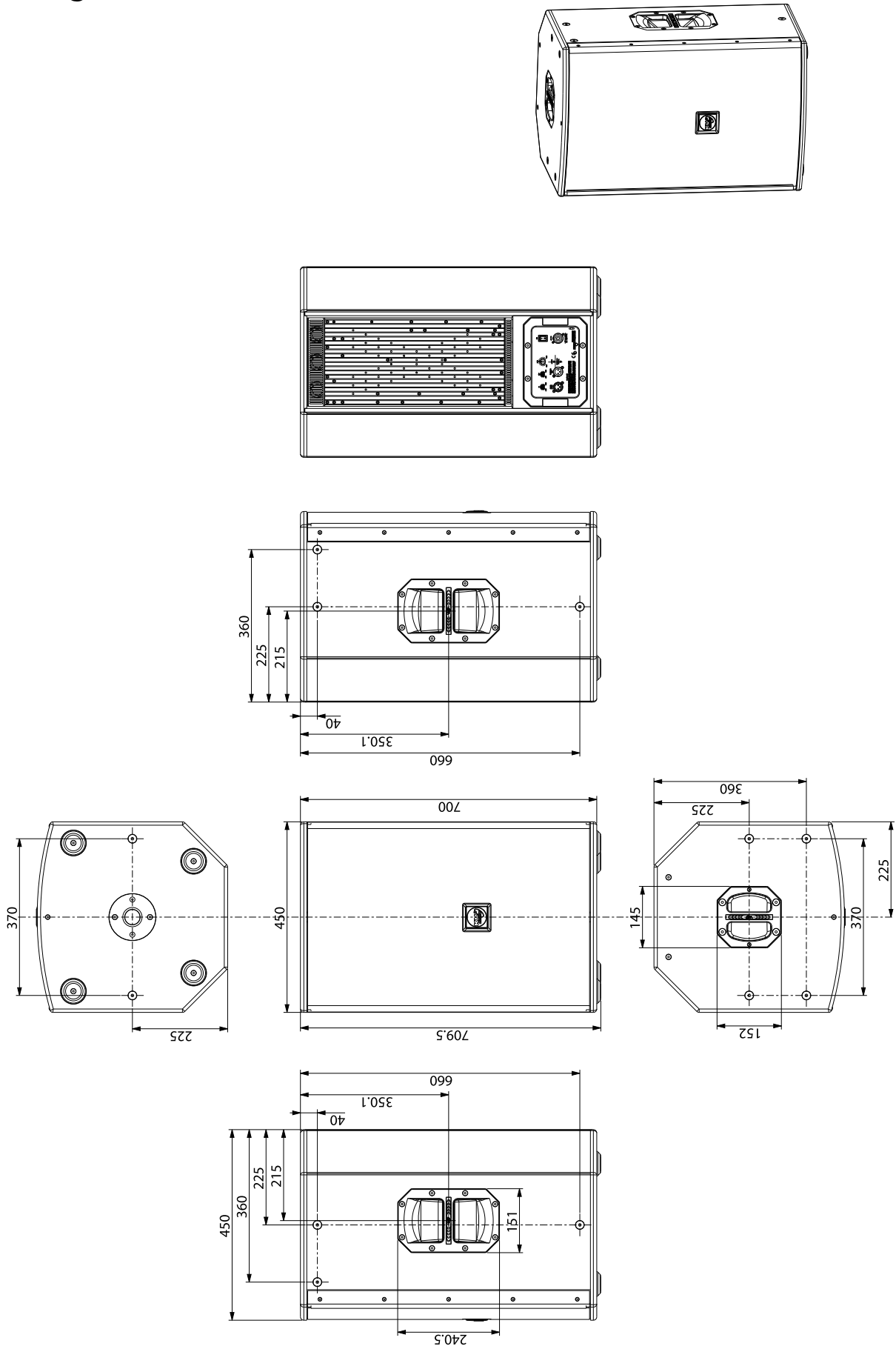

PADDED HEAVY DUTY COVERS

Cover for EX6

part name:
Cover EX6
 part number:
KVV 987 159
 description:
 - heavy duty
 - padded



Cover for EX26

part name:
Cover EX26
 part number:
KVV 987 209
 description:
 - heavy duty
 - padded



Cover for EX10

part name:
Cover EX10
 part number:
KVV 987 068
 description:
 - heavy duty
 - padded



Cover for EX12

part name:
Cover EX12
 part number:
KVV 987 067
 description:
 - heavy duty
 - padded



Weatherproof cover for EX12

part name:
Rainproof cover for EX12
 part number:
KVV 987 190
 description:
 - sound-permeable



Weatherproof cover for EX15

part name:
Rainproof cover for EX15
 part number:
KVV 987 518
 description:
 - for EX15
 - sound-permeable

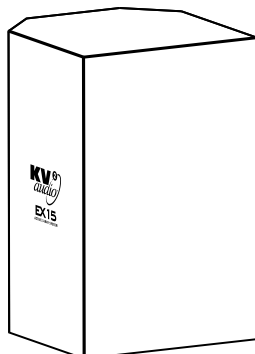

HORIZONTAL BRACKET

Horizontal Bracket for EX6

part name:
EX6 Horizontal Bracket
 part number:
KVV 987 495
 description:
 - black
 - including two connection bolts and bracket

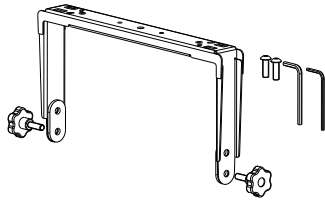

Horizontal Bracket for EX26

part name:
EX26 Horizontal Bracket
 part number:
KVV 987 493
 description:
 - black
 - including two connection bolts and bracket

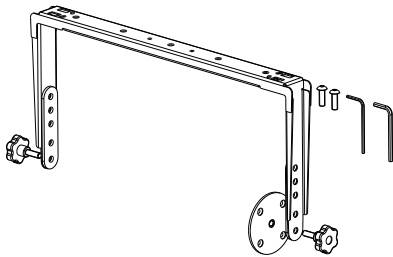

Horizontal Bracket for EX10

part name:
EX10 Horizontal Bracket
 part number:
KVV 987 486
 description:
 - for EX10, ESD10
 - black
 - including two connection bolts and bracket

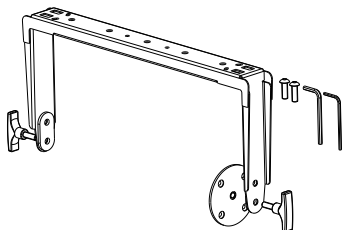

Horizontal Bracket for EX28

part name:
EX28 Horizontal Bracket
 part number:
KVV 987 533
 description:
 - for EX28
 - black
 - including two connection bolts

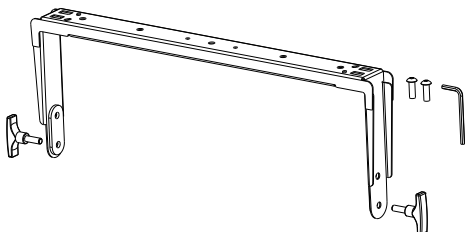

VERTICAL BRACKET

Vertical Bracket for EX6

part name:
EX6 Vertical Bracket
 part number:
KVV 987 484
 description:
 - for EX6, ESD6
 - black
 - including two connection bolts

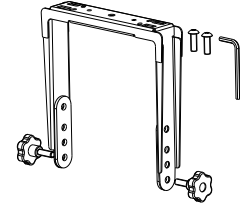

Vertical Bracket for EX26

part name:
EX26 Vertical Bracket
 part number:
KVV 987 492
 description:
 - black
 - including two connection bolts

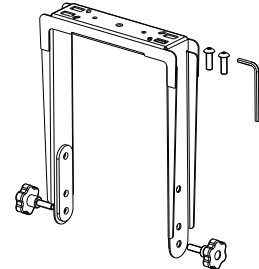

Vertical Bracket for EX10

part name:
EX10 Vertical Bracket
 part number:
KVV 987 485
 description:
 - for EX10, ESD10
 - black
 - including two connection bolts

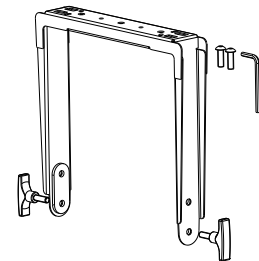

Vertical Bracket for EX28

part name:
EX28 Vertical Bracket
 part number:
KVV 987 532
 description:
 - for EX28
 - black
 - including two connection bolts

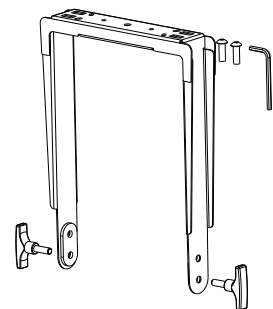

Horizontal bracket for EX12

part name:
EX12 Horizontal Bracket
 part number:
KVV 987 058
 description:
 - for EX12
 - black
 - including two connection bolts and bracket

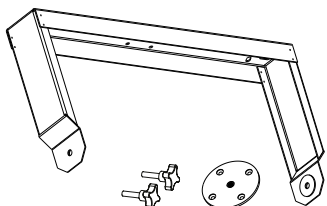

Vertical bracket for EX12

part name:
EX12 Vertical Bracket
 part number:
KVV 987 488
 description:
 - for EX12, ESD12
 - black
 - including two connection bolts

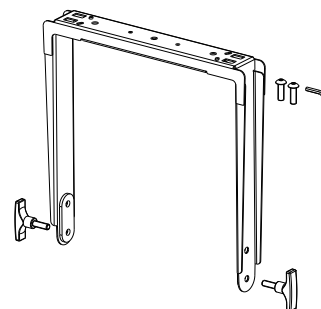

EX12 Vertical Bracket Double

part name:
EX12 Vertical Bracket Double
 part number:
KVV 987 152
 description:
 - for 2x EX12
 - bolts included
 - black

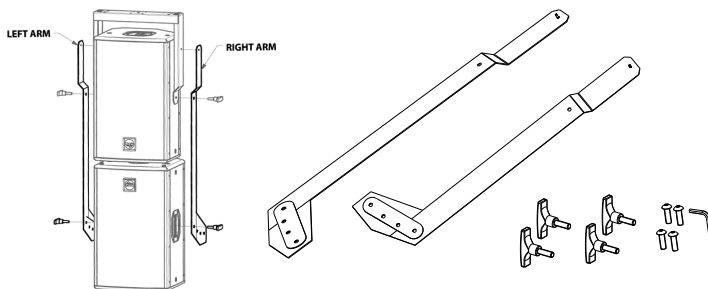

Horizontal bracket for EX15

part name:
EX15 Horizontal Bracket
 part number:
KVV 987 035
 description:
 - black
 - including top hat cover adaptor plate and two connection bolts and bracket

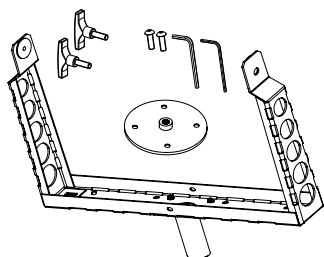

Vertical bracket for EX15

part name:
EX15 Vertical Bracket
 part number:
KVV 987 032
 description:
 - black
 - including two connection bolts

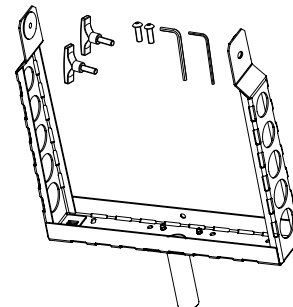

Bracket Top Hat Adapter

part name:
Top Hat Adapter
 part number:
KVV 987 090
 description:
 - for vertical and horizontal brackets
 - including bolts
 - black

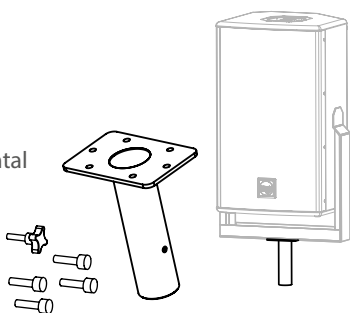

Pole mount adaptor for EX6

part name:
Pole mount adaptor
 part number:
KVV 987 151
 description:
 - black
 - including locking bolt

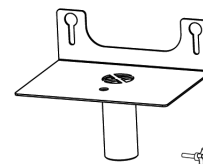

Grill fine options for EX6, EX26, EX10 and EX12

Grill - fine for EX6

part name:

EX6 Grill - fine

part number:

KVV 987 350

description:

- elegant design
- suitable for installations

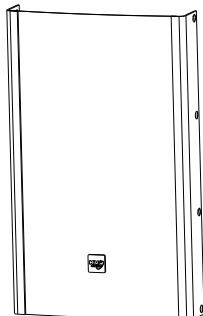

Grill - fine for EX26

part name:

EX26 Grill - fine

part number:

KVV 987 351

description:

- elegant design
- suitable for installations

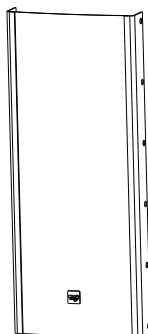

Grill - fine for EX10

part name:

EX10 Grill - fine

part number:

KVV 987 330

description:

- elegant design
- suitable for installations

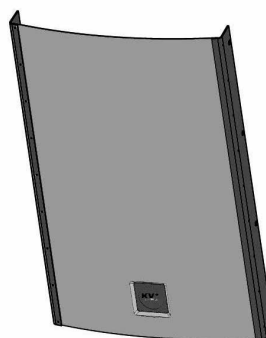

Grill - fine for EX12

part name:

EX12 Grill - fine

part number:

KVV 987 329

description:

- elegant design
- suitable for installations

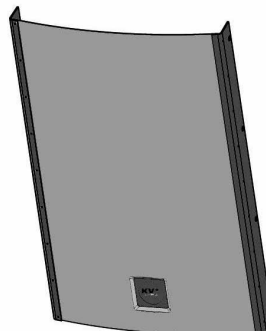

Speaker pole - universal

part name:
KV2-H
part number:
KVV 987 130

description:
- Heavy duty telescopic
speakerpole
- 0.735 to 1.23 m
- diameter 35 mm
- weight 2.2 kg
- max. load 50 kg
- bottom terminal M20
- matte black



Rotating the EX10 / EX12 Horn

The EX10 / EX12 horn can be rotated ninety degrees in order to accommodate applications where the speaker will be used or installed horizontally.

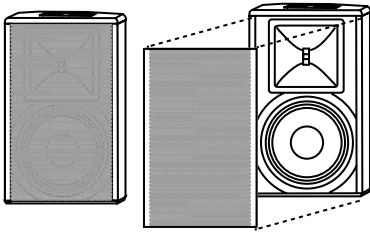

This can be accomplished by removing the front grill.

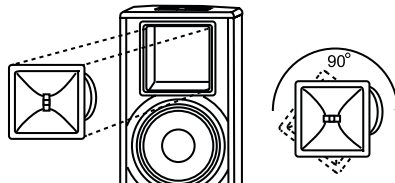

Removing the horn, rotating and replacing the horn.

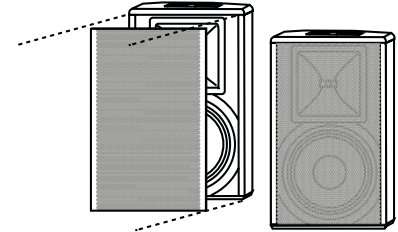

Replacing the front grille.

Warranty

Your EX Series Speakers is covered against defects in material and workmanship.

Refer to your supplier for more details.

Service

In the unlikely event that your EX Series Speakers develops a problem, it must be returned to an authorised distributor, service centre or shipped directly to our factory. Because of the complexity of the design and the risk of electrical shock, all repairs must be attempted only by qualified technical personnel.

If the unit needs to be shipped back to the factory, it must be sent in its original carton. If improperly packed, the unit may be damaged.

To obtain service, contact your nearest KV2 Audio Service Centre, Distributor or Dealer.



The Future of Sound.
Made Perfectly Clear.

KV2 Audio International

Nádražní 936, 399 01 Milevsko
Czech Republic

Tel.: +420 383 809 320

Email: info@kv2audio.com

www.kv2audio.com

KVV120118-00-05-0