



Disarray

User Guide

The correct theory of arraying KV2 boxes

Content

Disarray	3 - 7
The Theory	3
ES1.0	4
VHD2.0	5
EX10 & EX12	6 - 7

The Theory

The theory behind this stems from several different levels. Firstly the way our ears work, their position on our heads and the brains understanding of the signals they produce. With our ears positioned on each side of our head rather than on the top and bottom they are very good at pinpointing very precisely a sound in the Horizontal plane (i.e. it's exact position left to right in the sound field) Vertically trying to pin point sound up and down they are far less accurate and have a greater tolerance for error.

The second problem with KV2 speakers is that they are far more accurate, defined and Phase coherent than virtually any other speaker on the market. Whilst in the correct hands this can produce stunning and exceptional results, when used incorrectly the results can be devastatingly poor. Badly recorded MP3's, poor mixing consoles or a rough engineer will all show up much more clearly on a KV2 system and the uneducated will often blame the system before they look for the real cause of the problem. Of course you can easily show them by replacing the poor quality elements of the set up that the speakers are just showing you very accurately what is really there.

This very defined phase accuracy also comes into play when trying to stack the speakers side by side, as well as cancelling out perfectly which reduces overall output, each ear will now be hearing in the horizontal plane two sources very close together, but very slightly misaligned in arrival time. Being so phase coherent but misaligned leads the brain to get confused which in turn leads it to interpret a confused poor quality, low intelligibility sound.

KV2 exploits the additional vertical tolerance that the brain has by only stacking multiple cabinets vertically, as do modern Line arrays, but KV2 still keeps as close as possible to the theory of point source by using a maximum of two cabinets together. This reduces the cancellations that most line arrays suffer from particularly in the high frequencies.

The only exception to this maximum of two cabinets would be in a down fill / side fill application where an additional cabinet can be deployed but must be separated from the main forward firing system by an amount of degrees equivalent to the vertical or horizontal dispersion of that speaker.

Combining boxes and building systems in this way will give the maximum overall output, best Audio quality and consistent, even coverage.

Please do not allow yourselves, employees or customers to represent KV2 in a way that will be detrimental to its performance, enjoyment, and overall reputation - for the benefit of all of us who care about true audio.



Disarray

Very Important - The correct theory of arraying KV2 boxes

A recent number of situations have arisen where distributors and end users have tried to array KV2 speakers in a way that produces very poor quality results.

Standing two ES 1.0's or VHD 2.0's side by side will actually produce lower output and less coherent sound than using just one single box. Please see the pictures below and over leaf which demonstrate how to use multiple boxes correctly.

ES1.0

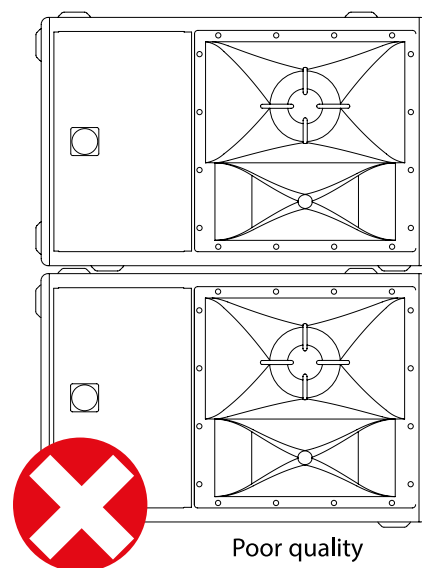
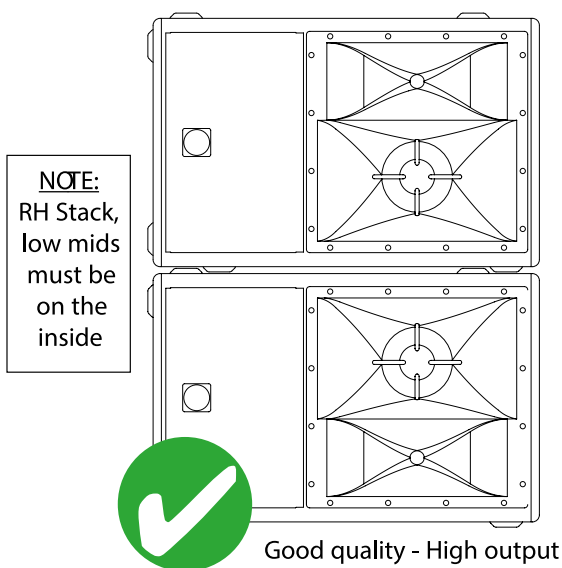
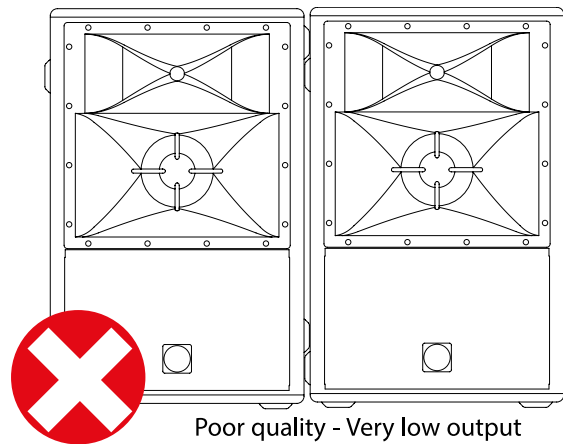
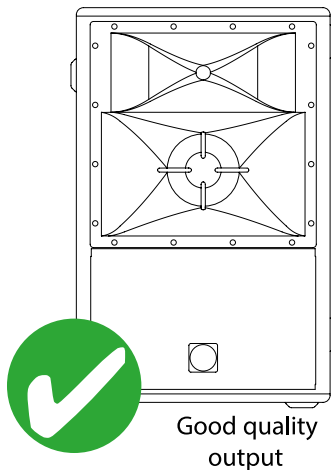

VHD2.0

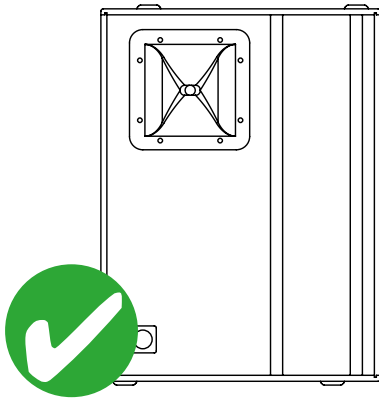

Good quality output
High Intelligibility

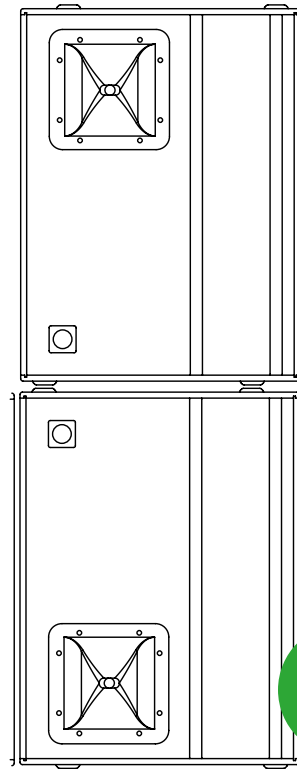

NOTE:
RH Stack, low
mids must be
on the outside
(opposite to ES1)

Good quality very
high output
Long throw
High Intelligibility

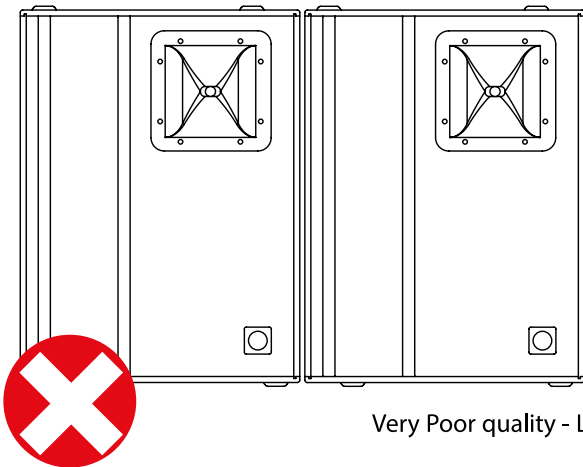

Very Poor quality - Low output - Low Intelligibility

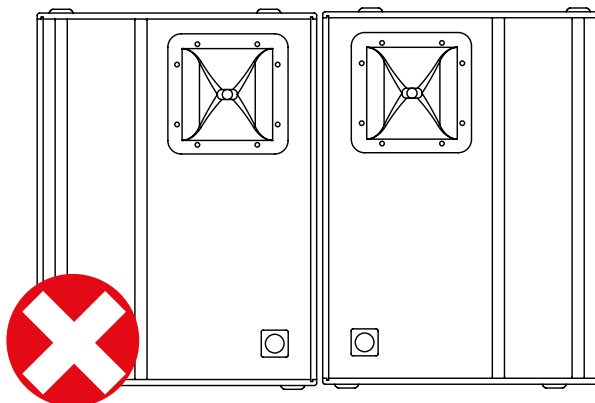
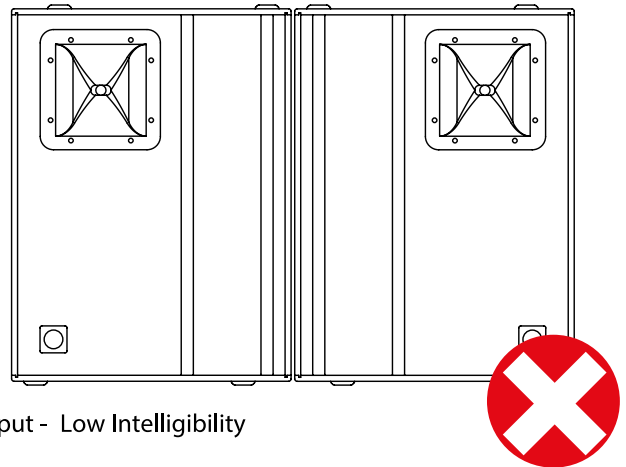

Disarray · VHD2.0

EX10 & EX12

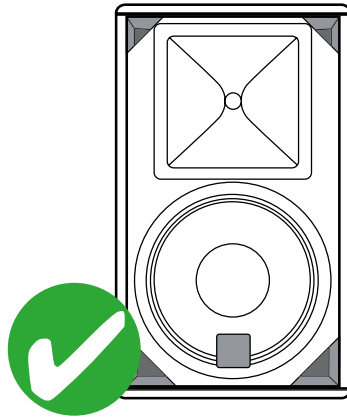

Good quality

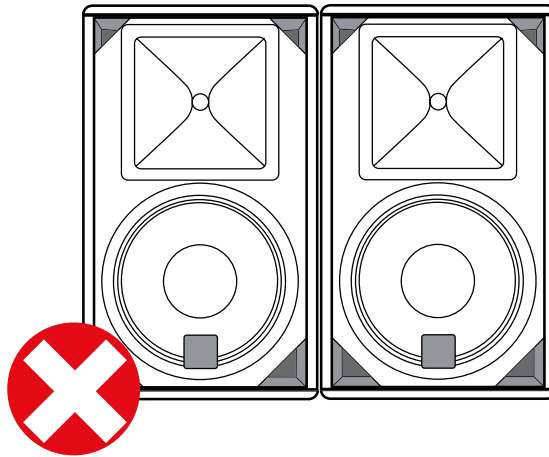

Poor quality,
reduced output

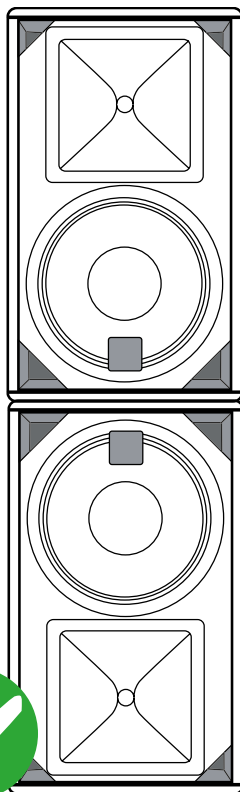

Not an ideal scenario
but workable where 2
cabinets must be used

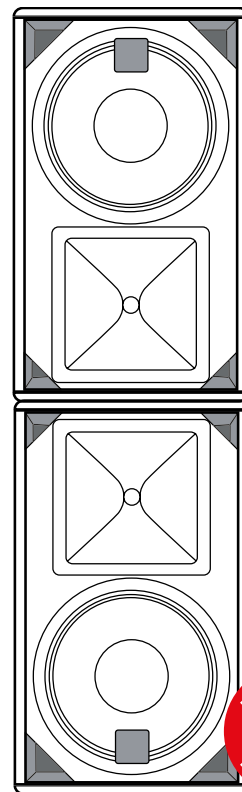

Poor quality,
reduced output

EX12 ONLY

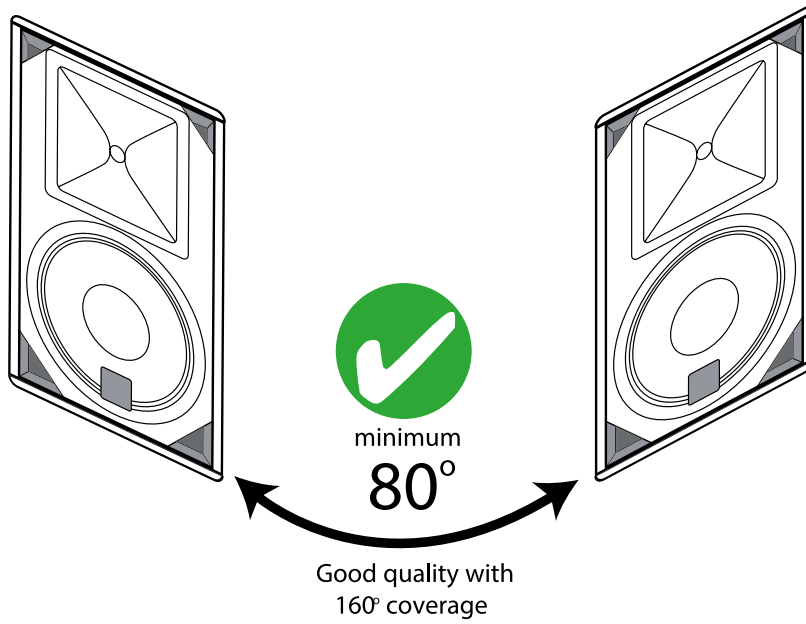

EX10 ONLY

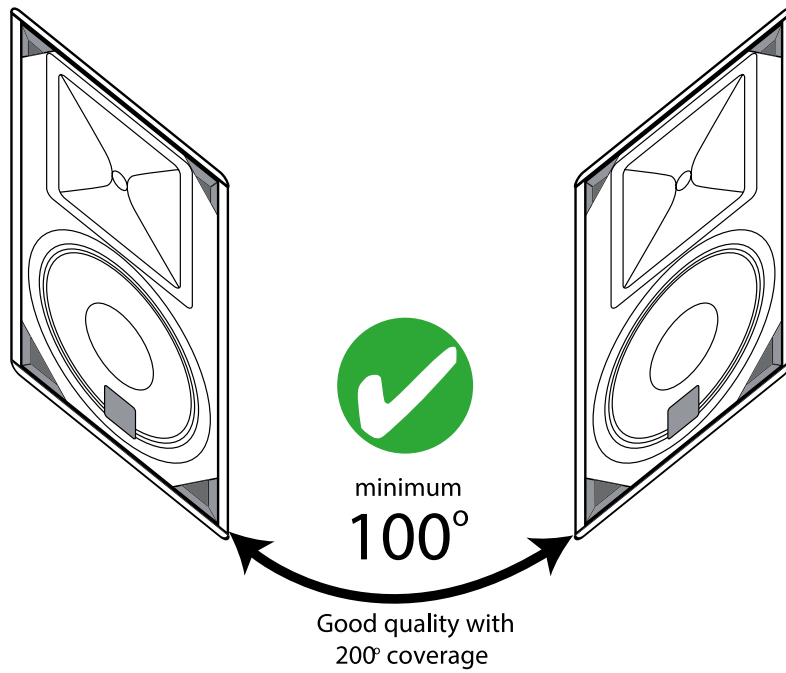



The Future of Sound.
Made Perfectly Clear.

KV2 Audio International

Nádražní 936, 399 01 Milevsko
Czech Republic

Tel.: +420 383 809 320

Email: info@kv2audio.com

www.kv2audio.com

KVV120157-00-01-0