

Introduction

The SL2.15 is a double 15" direct radiation subwoofer system with augmented bass reflex. Built to integrate aesthetically with the SL412 the SL2.15 produces deep bass from its slim cabinet design. Bass response is enhanced by coupling when the SL2.15 is used against or in a wall, providing optimum output for it's small footprint. It also combines beautifully with the Ultra Low Frequency VHD1.21 and 2.21 subwoofers as part of a five way active system.

Features

- Slim, discreetly profiled wall mount cabinet
- 129dB sustained output, 132dB peak with very high dynamic range
- Simple wall mounting, suspension and ground stacking options and can be installed internally into walls and surfaces
- These units can be designed and supplied with custom colors, grill templates and logos, offering a flexible and truly designer integrated product
- A single horizontal yoke assembly with multiple fixed angles and fixing locations, provides a quick and cost effective solution for simple suspension
- Front-loaded, 2x 15" bass drivers with 3" voice coil assembly and ferrite magnetic motor structure
- Professional, exterior-grade Baltic birch construction with wear-resistant polymer coating
- Proprietary side handle design for simplified handling and carrying
- Internal back braces with nine M10 suspension points
- A total of 23 suspension points are available for custom installation applications
- Two SL2.15 speakers require one channel of two channel VHD3200 subwoofer amplifier unit
- The SL412i & SL2.15i are identical in performance and finish as the existing SL412 & SL2.15, except they do not incorporate the fixed handles for touring and presentation use. The 'I' version is designed for fixed installation use with the same existing mounting and flyware fixings



Application

Specifically designed subwoofer enclosure to accompany the SL412 as a high powered aesthetically pleasing full range music playback and performance system

- Fixed installation
- Nightclubs
- Multi use venues

System Acoustic Performance	
Max SPL Long-term	129dB
Max SPL Peak	132dB
-3dB Response	40Hz to 500Hz
-10dB Response	35Hz to 500Hz
Sensitivity	100dB
Impedance	8Ω
Crossover Point	70Hz
Low Frequency Section	
Acoustic Design	Direct-Radiating with Bass Reflex
Subwoofer Amplifier Requirement	1600W / 2x SL2.15 (VHD3200 amp.)
Number of Drivers	2
Woofer Size / Voice Coil Diameter / Design	2x 15" / 3" / Inside Outside
Magnet Type	Ferrite
Diaphragm Material	Epoxy Reinforced Cellulose

Speaker Input	
Speaker Input	AP4
Speaker Output	
Speaker Output	AP4
Cabinet	
Cabinet Material	Baltic birch
Handles	2
Color	"Orange peeled" Matt Black or any RAL
Physical Dimensions	
Height	960 mm (37.8")
Width	1080 mm (42.52")
Depth	350 mm (13.78")
Weight	61 kg (134.5lbs)

Architectural Specifications

The bass module loudspeaker system shall incorporate two 15-inch low frequency (LF) transducer with ferrite motors and 3-inch polyimide, high-temperature voice coils. The LF driver shall be mounted inside a compact wood enclosure with bass reflex design.

The loudspeaker enclosure shall have a slim shape and shall incorporate two side handles with integrated M10 suspension points and incorporate integrated internal braces with 23 M10 suspension points. The speaker cabinet shall be finished with an ultra wear resistant black polymer coating and fitted with a weather resistant perforated steel grill.

This speaker shall receive power from a separate subwoofer amplifier module (VHD3200) including speaker protection.

The speaker system shall connect to the amplifier module via proprietary cables terminated in Amphenol AP-4 connectors.

Dimensional Drawings

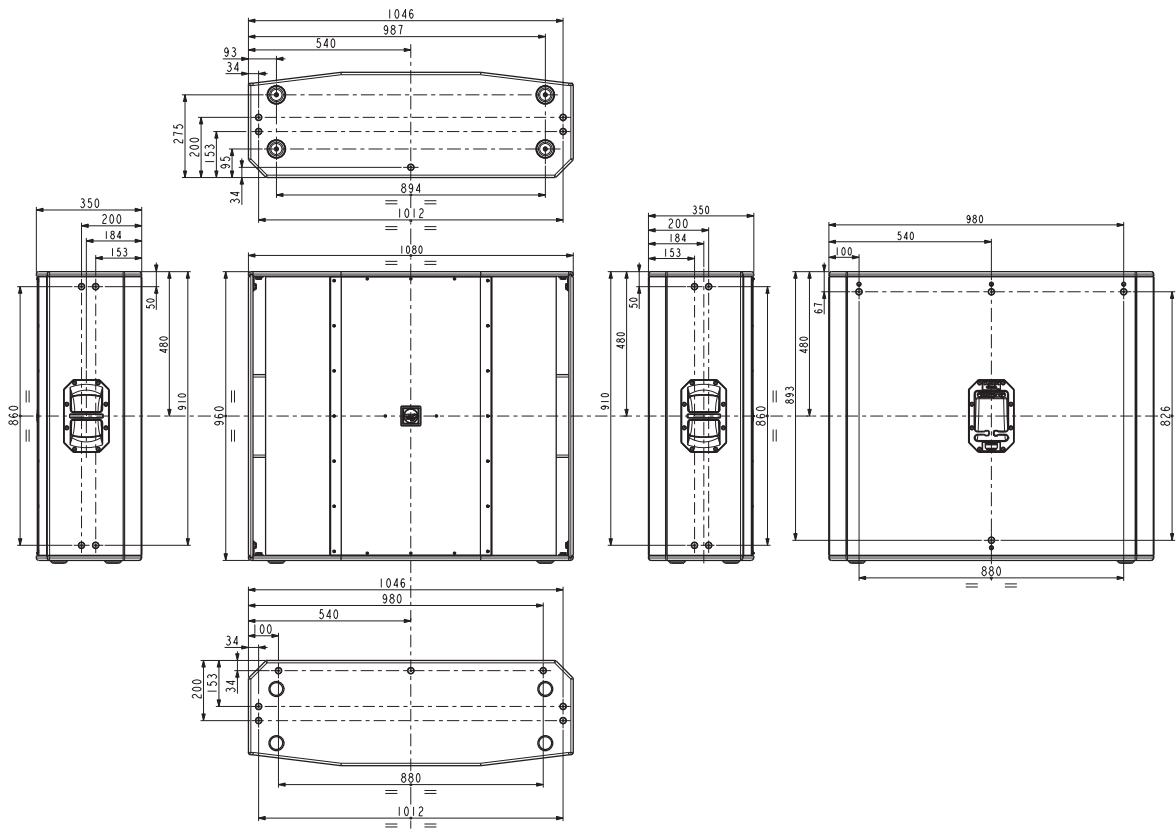

The future of sound. Made perfectly clear.



KV2 Audio International, Nádražní 936, Milevsko 399 01, Czech Republic

Tel.: +420 383 809 320

Email: info@kv2audio.com | Web: www.kv2audio.com