

VHD1.0 Technical Data Sheet

Introduction

The VHD1.0 downfill enclosure features a single 12" low mid woofer, an 8" transcoil mid-range woofer and the same compression driver as the VHD2.0 on a wide angle 110° horizontal by 40° vertical horn. The rear of the box has been angled for use as a downfill with the VHD2.0. Alternatively as a stand-alone box up to three VHD1.0s can be powered from a single VHD2000 amplifier. Like the VHD2.0, VHD1.0 is available in left and right versions for downfill applications. Designed to be powered as a slave from the VHD2.0 cabinet or directly from the VHD2000 amplifier, all equalization, set up and level are preset providing a plug and play solution for large scale touring and high quality installation.

Features

- Professional Baltic birch construction with wear-resistant polymer coating
- Cut away down angle for correct positioning when flown underneath VHD2.0 cabinet
- Four pieces of fly-track (two per side)
- Very High Definition audio reproduction
- 134dB sustained output, 137dB peak
- Controlled wide dispersion 110° x 40° Mid/High horn with a flat response to 180°
- Revolutionary 3" (76 mm) Nitride Titanium diaphragm compression driver with complex geometry phase plug and neodymium magnetic structure for higher output, exceptionally low distortion and extended frequency response
- 8" Trans-Coil midrange driver, with a 3" (76 mm) voice coil and neodymium magnet for increased control and output with reduced distortion and weight. Horn loaded 12" mid-bass driver with 3" (76 mm) inside/outside, epoxy baked, high temperature voice coil assembly and neodymium magnetic structure
- Three way active requirement - 1000W from the VHD 2000 providing 600W for the 12" Low Mid, 300W for the 8" Midrange and 100W for the High Frequency
- Proprietary side handle design (3) for simplified handling and carrying
- High impact low friction feet, allowing lock- in to other VHD cabinets and easy cabinet movement
- Front locking aluminium VHD wheel boards with wraparound hardwood bumpers
- Weather proofing option and special paint finishes available on request



Application

Designed as a true mid high - downfill enclosure to accompany the VHD2.0 as part of the VHD systems

- Medium to large concert venues
- Fixed installation
- Outdoor events

System Acoustic Performance	
Max SPL Long-term	134dB
Max SPL Peak	137dB
-3dB Response	100Hz to 22kHz
-10dB Response	85Hz to 30kHz
-3dB Response (Full Range mode)	65Hz to 22kHz
Crossover Point	100Hz, 450Hz, 2.2kHz

High Frequency Section	
Acoustic Design	Horn Loaded
High Horn Coverage Horizontal / Vertical	110° x 40°
High Frequency Amplifier Requirement	100W (VHD200 amp.)
Throat Exit Diameter / Diaphragm Size	1.4" / 3.0"
Diaphragm Material	Nitride Titanium
Magnet Type	Neodymium

Mid Range Section	
Acoustic Design	Horn Loaded
Mid Horn Coverage Horizontal / Vertical	110° x 40°
Midrange Amplifier Requirement	300W (VHD2000 amp.)
Woofer Size / Voice Coil Diameter / Design	8" / 3.0" / Trans Coil
Diaphragm Material	Epoxy Reinforced Cellulose
Magnet Type	Neodymium

Mid-Bass Section	
Acoustic Design	Horn Loaded
Mid-bass Amplifier Requirement	600W (VHD2000 amp.)
Woofer Size / Voice Coil Diameter / Design	12" / 3" / Inside Outside
Diaphragm Material	Epoxy Reinforced Cellulose
Magnet Type	Neodymium

Speaker Input	
Speaker Input	AP6 male

Speaker Output	
Speaker Output	AP6 female

Cabinet	
Cabinet Material	Baltic birch
Handles	4
Color	"Orange peeled" Matt Black or any RAL

Physical Dimensions	
Height	660 mm (25.98")
Width	700 mm (27.55")
Depth	495 mm (19.48")
Weight	45 kg (99lbs)

VHD1.0 Technical Data Sheet

Architectural Specifications

The Loudspeaker shall be a 3-way Horn loaded design, using SLA Technology - (Super Live Audio), and shall only be driven and controlled by a dedicated – matched Amplifier Controller.

The Loudspeaker enclosure shall consist of one 12" Neodymium magnet structure Mid Bass driver, one 8" Neodymium magnet structure Mid-range driver featuring AIC technology and one 3" Nitride Titanium Compression driver mounted to a low compression, low Q horn assembly. The cabinet enclosure shall be made from re-enforced Baltic Birch Ply, with toughened impact and wear resistant paint finish.

The Loudspeaker woofer components shall be protected by an acoustically full size transparent rigid metal grille supported by absorbent rubber seals. The enclosure shall incorporate one ergonomically designed recessed handle in each side panel and shall incorporate an additional single handle on the top angled panel. The enclosure shall incorporate one short angled Aeroquip fly track rail on each side panel, to facilitate overhead vertical enclosure suspension and connection to the VHD2.0 Enclosure by employment of a dedicated FLYBAR System. The enclosure shall include four high impact, low friction feet on the bottom panel to allow enclosure locking into other VHD cabinets and easy movement.

The enclosure shall incorporate a recessed connection panel with integral cable secure point and will be fitted with a single input Amphenol AP6 locking connector and a corresponding thru/output for connection to the VHD2.0. The enclosure shall include two recessed Butterfly clip receptacles on each side panel for attachment of a protective Wheel board. The Loudspeaker shall have a maximum long term pressure level of 134dB, have a total peak power handling capacity of 1000w, with a nominal Horizontal dispersion of 110 deg and a Vertical of 40 deg and have a measured on axis frequency response of 100Hz to 22KHz (-3dB), 85Hz to 30kHz (-10dB).

The Enclosure dimensions shall be: 660 mm / 25.98" x 700 mm / 27.55" x 495 mm / 19.48"

The Enclosure shall not exceed a weight of 45 kg / 99lbs.

The Loudspeaker shall be the KV2 Audio VHD1.0.

The dedicated Amplifier/Controller shall be the KV2 Audio VHD2000. The dedicated fly ware shall be the VHD FLYBAR System.

Dimensional Drawings

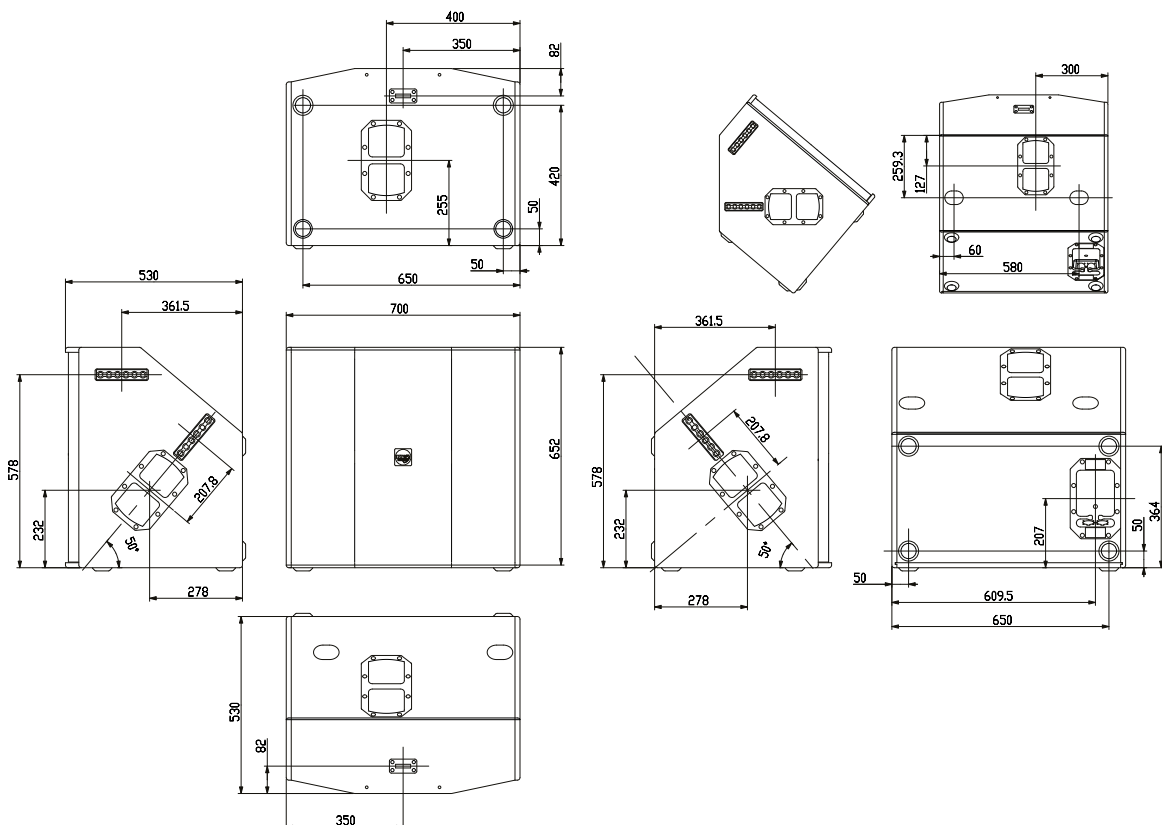

The future of sound. Made perfectly clear.



KV2 Audio International, Nádražní 936, Milevsko 399 01, Czech Republic

Tel.: +420 383 809 320

Email: info@kv2audio.com | Web: www.kv2audio.com